



**AANLS 20K / AAL 23K / AAL 25K
AAL 30K / AAEDL 30K
SPECIFICATIONS**

LIT NO: L729

DATE: March 2003

REVISION: B

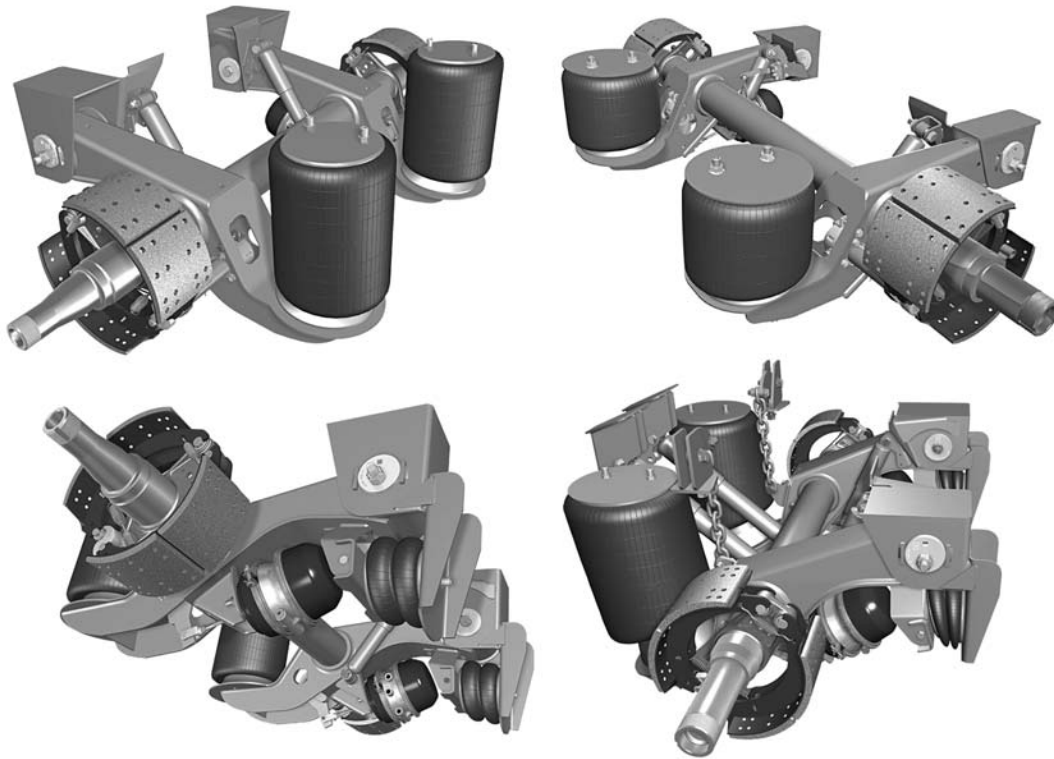

TABLE OF CONTENTS

APPLICATIONS2, 3, 4
SPECIFICATIONS	
Suspensions — AANLS 20K/AAL 23K/AAL 25K/AAL 30K/AAEDL 30K2, 3, 4
Brake Options5
Brake Rating5
Brake Chambers5
Slack Adjusters5
READY-TO-ROLL® Options5
Axle6
Height Control Valve Kits6
Lift Mechanism6

AANLS 20K



*CAPACITY	20,000 lbs. (9 100 kg)	
TRAILER TYPES	UNITED STATES & CANADA On-highway Autohauler Drop-Frame van High-Cube van Pup van	MEXICO, CENTRAL & SOUTH AMERICA None
AXLE ARRANGEMENT	Single; Tandem up to 60-inch maximum spacing; Tri- or quad-axle up to 144-inch maximum total spacing	
FRAME TYPES	Steel 96- or 102-inch wide trailers	
BASE MODEL DESCRIPTION	INTRAAX® low-ride suspension/axle, 6.25-inch ride height, weld-on winged frame brackets with QUIK-ALIGN®, 71.5-inch axle track, HN spindles, standard shock absorbers, 16.5 x 7-inch brakes with Abex 3030-197 brake lining and ABS brackets. Cam Tube System included as standard.	
BASE MODEL WEIGHT	518 lbs.	
OTHER OPTIONS	Additional options include extended-service/high-damping shock absorbers, shock straps, rear-mounted shock absorbers. Ride heights ranging from 6.25 to 12 inches are available, as well as choices for 73, 75.5, 76.5, 77.5, 83.5 and 85-inch axle track, 16.5 x 8.625-inch or 15 x 8.625-inch brakes, HP or HUS® spindles and dust shields. Contact your Hendrickson representative to discuss these and other options, including a variety of READY-TO-ROLL®, brake and wheel-end packages.	

**Capacity refers to suspension and axle ratings. Ratings for brakes and wheel-end components differ depending upon options chosen.*

SPECIFICATIONS

SUSPENSION — AANLS 20K

RIDE HEIGHT (inches)	JOUNCE (inches)	REBOUND (inches)
6.25	1.9	5
7	2.6	4.3
9	2.8	3.8
12	3.3	3.4

AANLS 20K/AAL 23K/AAL 25K/AAL 30K/AAEDL 30K — SPECIFICATIONS



AAL 23K



AAL 25K

*CAPACITY	23,000 lbs. (10 400 kg)		25,000 lbs. (11 300 kg)	
TRAILER TYPES	UNITED STATES & CANADA	MEXICO, CENTRAL & SOUTH AMERICA	UNITED STATES & CANADA	MEXICO, CENTRAL & SOUTH AMERICA
	Drop-Deck Platform Lowboy Dump — Bottom Discharge Tanker Grain Livestock Curtain-Side	None	Platform Lowboy Drop-Deck Dump Tanker Grain Livestock Curtain-Side	Van/Reefer Drop Frame Van Auto Hauler Container Chassis Platform Lowboy Drop-Deck Grain Livestock Curtain-Side
AXLE ARRANGEMENT	Single; Tandem up to 122-inch maximum spacing; Tri- or quad-axle up to 144-inch maximum total spacing			
FRAME TYPES	Steel, aluminum or composite; 96- or 102-inch wide trailers			
BASE MODEL DESCRIPTION	INTRAAX® low-ride/liftable suspension/axle, 6.5-inch ride height, weld-on, winged frame brackets with QUIK-ALIGN®, 71.5-inch axle track, HN spindles, standard shock absorbers, 16.5 x 7-inch brakes with Abex 3030-197 brake lining and ABS brackets. Cam Tube System included as standard.			
BASE MODEL WEIGHT	578 lbs.		601 lbs.	
OTHER OPTIONS	Additional options include wingless and bolt-on frame brackets, extended-service/high-damping shock absorbers, shock straps, rear-mounted shock absorbers, rebound limiters and HIGH CONTROL. Ride heights ranging from 6.5 to 19 inches are available, as well as choices for 73, 76.5, 77.5, 83.5 and 85-inch axle track, 15 x 8.625-inch brakes, HP or HUS® spindles and dust shields. Contact your Hendrickson representative to discuss these and other options, including a variety of READY-TO-ROLL®, brake and wheel-end packages.			

*Capacity refers to suspension and axle ratings. Ratings for brakes and wheel-end components differ depending upon options chosen.

SPECIFICATIONS

SUSPENSION — AAL 23K/AAL 25K

RIDE HEIGHT (inches)	JOUNCE (inches)	REBOUND ¹ (inches)
6.5	2.3	4.5
7.5	3.3	3.5
9	4.8	4.2
12	5.3	4.8
14	5.9	4.4

RIDE HEIGHT (inches)	JOUNCE (inches)	REBOUND ¹ (inches)
15	5.6	3.4
16	5.7	4.3
17	6.0	3.3
19	5.7	3.5

¹Limited rebound is also available

AANLS 20K/AAL 23K/AAL 25K/AAL 30K/AAEDL 30K — SPECIFICATIONS



AAL 30K



AAEDL 30K (Extreme-Duty)

*CAPACITY	30,000 lbs. suspension (13 600 kg) 25,000 lbs. axle (11 300 kg)		30,000 lbs. (13 600 kg)	
TRAILER TYPES	UNITED STATES & CANADA Platform Drop-Deck Lowboy Dump	MEXICO, CENTRAL & SOUTH AMERICA Van/Reefer Platform Drop-Deck Lowboy Curtain-Side	UNITED STATES & CANADA Logger Chip Van Dump	MEXICO, CENTRAL & SOUTH AMERICA Platform Drop-Deck Tanker Dump Logger Sugar Cane
AXLE ARRANGEMENT	Single; Tandem up to 122-inch maximum tandem spacing; Tri- or quad-axle up to 144-inch maximum total spacing			
FRAME TYPES	Steel, aluminum or composite; 96- or 102-inch wide trailers			
BASE MODEL DESCRIPTION	INTRAAX® low-ride suspension/axle, 9-inch ride height, weld-on, winged frame brackets with QUIK-ALIGN®, 71.5-inch axle track, HN spindles (AAL 30K) HP spindles, (AAEDL 30K), extended service/high damping shock absorbers, 16.5 x 7-inch brakes with Abex 3030-197 brake lining and ABS brackets. Cam Tube System included as standard.			
BASE MODEL WEIGHT	629 lbs.		665 lbs.	
OTHER OPTIONS	Additional options include wingless and bolt-on frame brackets, shock straps, rear-mounted shock absorbers, rebound limiters and HIGH CONTROL. Ride heights ranging from 9 to 19 inches are available, as well as choices for 73, 76.5, 77.5, 83.5 and 85-inch axle track, 15 x 8.625-inch brakes (AAL 30K), HP spindles (AAL 30K) and dust shields. Contact your Hendrickson representative to discuss these and other options available, including a variety of READY-TO-ROLL®, brake and wheel-end packages.			

*Capacity refers to suspension and axle ratings, except where noted. Ratings for brakes and wheel-end components differ depending upon options chosen.

SPECIFICATIONS

SUSPENSION — AAL 30K

RIDE HEIGHT (inches)	JOUNCE (inches)	REBOUND ¹ (inches)
9	4.5	4.2
12	5.3	4.8
14	5.9	4.4
15	5.6	3.4
16	5.7	4.3
17	6.0	3.3
19	5.7	3.5

SUSPENSION — AAEDL 30K

RIDE HEIGHT (inches)	JOUNCE (inches)	REBOUND ¹ (inches)
9	4.6	4.0
12	5.3	4.6
14	5.9	4.3
15	5.6	3.3
16	5.7	4.2
17	6.0	3.2
19	5.7	3.4

¹Limited rebound is also available

BRAKE OPTIONS (For S-cam Brakes)

The following table is a listing of S-cam brake packages available with INTRAAX®. For complete details of the wide range of brake options available, including lining choices, brake ratings and FMVSS/CMVSS 121 brake certifications, refer to Publication L809.

BRAKE SIZE (inches)	BRAKE RATING (pounds)	AL FACTOR (chamber area × slack length)	TIRE ROLLING RADIUS ("SLR") (inches)
16.5 × 7 standard service	From 17,000 to 23,000	From 132 to 180 (From 24 x 5.5 to 30 x 6.0)	From 17.0 to 20.8
16.5 × 7 HXS® extended service	From 17,000 to 25,000	From 132 to 180	From 17.0 to 20.8
16.5 × 8.625 HXS extended service	From 17,000 to 25,000	From 132 to 180	From 17.0 to 20.8
15 × 8.625 HXS extended service	From 13,700 to 20,000	From 132 to 180	From 14.9 to 17.3

BRAKE CHAMBERS

CHAMBER TYPE	STROKE (inches)	PUSHROD LENGTH (inches)
24/24	STD 2.5	5.63
24/30	STD 2.5	5.63
30/30	STD 2.5	5.63
30/30	LONG 3.0	5.63
30/30 (6 yr.)	LONG 3.0	5.63
30/36	STD 2.5	5.63

SLACK ADJUSTERS

All industry standard 5.5- and 6-inch slack adjusters are compatible.

READY-TO-ROLL®

Choose from a broad mix of offerings to customize running gear for your specific application. Wheel-end options in aluminum, ductile iron or ADI, in a variety of standard and extended service packages, including our HUS® unitized system with a 7-year/750,000-mile warranty. HTIS™ Tire Inflation System also available.

AANLS 20K/AAL 23K/AAL 25K/AAL 30K/AAEDL 30K — SPECIFICATIONS

AXLE

SPINDLE TYPE	WHEEL BEARINGS			
	Inner Cone	Outer Cone	Inner Cup	Outer Cup
HN*	HM218248	HM212049	HM218210	HM212011
HP	HM518445	HM518445	HM518410	HM518410

* Not available on AAEDL 30K

HEIGHT CONTROL VALVE KITS — AAL

DUMP VALVE	NON-DELAY	
	1/4-inch tube fitting	3/8-inch tube fitting
WITHOUT	AKH-225-3	AKH-235-3
ADD-ON	AKHD-225-3	AKHD-235-3

NOTE: Bolted link shown — air kits with clamped link are also available

HEIGHT CONTROL VALVE KITS — AANLS

DUMP VALVE	NON-DELAY	
	1/4-inch tube fitting	3/8-inch tube fitting
WITHOUT	AKH-0265-3	AKH-0275-3

NOTE: Clamped link

LIFT MECHANISM

UNDER BEAM LIFT (UBL) and air controls sold separately.



Information contained in this literature was accurate at the time of publication. Product changes may have been made after the copyright date that are not reflected.

Trailer Suspension Systems
250 Chrysler Drive, Unit #3
Canton, OH 44707-2600 USA

866.RIDEAIR (866.743.3247)
330.489.0045
Fax 800.696.4416

www.hendrickson-intl.com