

H TECHNICAL PUBLICATION

RT2/RTE2-340 Thru 520

NO: 17730-070

SUBJECT: Springing: Spring Hangers and Spring
and Saddle Assembly

DATE: September 1994 REVISION: G

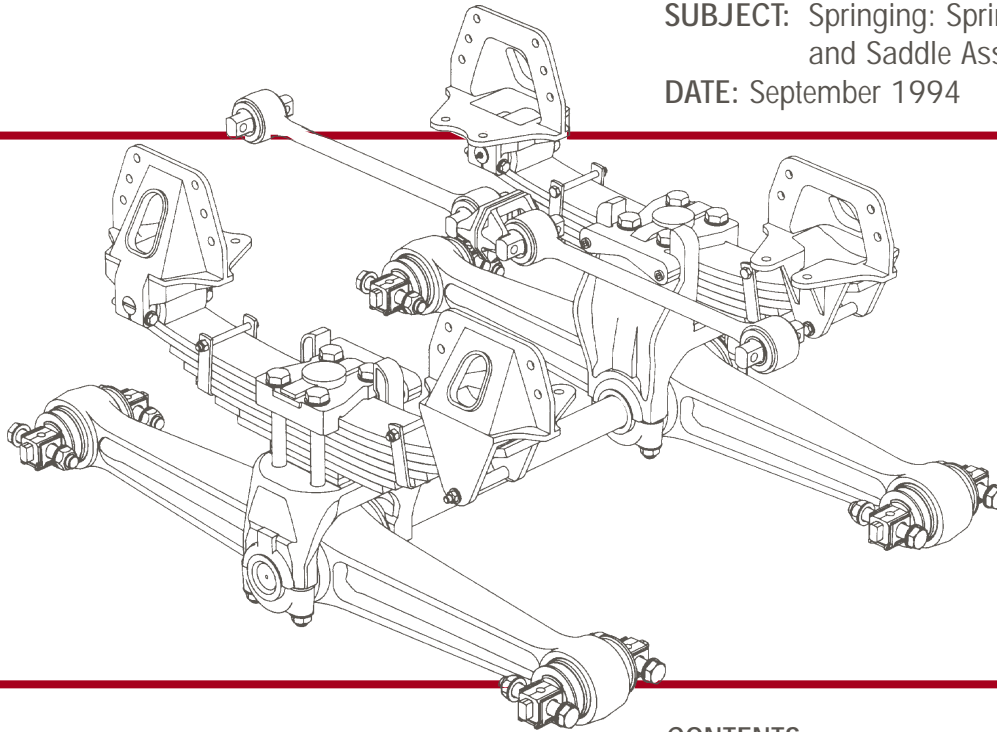

CONTENTS

Item	Subject	Page
1	Introduction	2
2	Important Safety Notices	2
3	RT2/RTE2 Series Description	3
4	Alignment	4
5	Preventive Maintenance	4-5
	Lubrication	4
	#1 Spring Hanger	4
	#2 Spring Hanger	4
	#3 Spring Hanger	4
	Spring Eye Pin Bushing	4-5
	Saddle Cap	5
	Spring	5
6	Disassembly	5-6
7	Reassembly	6-9
8	Tightening Torque Chart	10

H **HENDRICKSON**
Truck Suspension Systems

A Boler Company



Subject 1 INTRODUCTION

This publication is to acquaint and assist maintenance personnel in preventive maintenance and rebuild of the RT2/RTE2-340 through RT2/RTE2-520 series suspensions.

Use only genuine Hendrickson replacement parts for servicing these suspensions. Most Hendrickson parts can be identified by the Hendrickson  trademark.

Note the date of this publication. Hendrickson Truck Suspension periodically revises and updates this publication. If this copy is more than one year old, contact Hendrickson Truck Suspension to determine if a later copy is available.

Subject 2 IMPORTANT SAFETY NOTICE

Proper service and repair is important to the safe and reliable operation of the tandem suspension. The service procedures recommended by Hendrickson and described in this technical publication are effective methods of performing maintenance.

There are various warnings and cautions that should be read carefully to minimize the risk of personal injury and to assure that proper methods are used. Improper servicing may damage the vehicle or render it unsafe in operation.

WARNING:
HENDRICKSON TRUCK SUSPENSION SYSTEMS REMINDS USERS TO ADHERE TO THE PUBLISHED CAPACITY RATINGS FOR THE SUSPENSIONS. ADD-ON AXLE ATTACHMENTS AND OTHER LOAD TRANSFERRING DEVICES CAN INCREASE THE SUSPENSION LOAD ABOVE THE RATED AND APPROVED CAPACITIES WHICH COULD RESULT IN FAILURE AND LOSS OF VEHICLE CONTROL, POSSIBLY CAUSING PERSONAL INJURY OR PROPERTY DAMAGE.

ALUMINUM COMPONENTS WERE DESIGNED TO BE LIGHTWEIGHT OPTIONS WHERE WEIGHT REDUCTION IS DESIRABLE. THEIR USE SHALL BE CONFINED TO APPLICATIONS WHERE THE RATED CAPACITY OF THE SUSPENSION WILL NOT BE EXCEEDED. FAILURE TO LIMIT ALUMINUM COMPONENT APPLICATIONS TO RATED CAPACITY COULD RESULT IN CATASTROPHIC FAILURE OF THE COMPONENT AND LOSS OF VEHICLE CONTROL, POSSIBLY CAUSING PERSONAL INJURY OR

PROPERTY DAMAGE.

ALUMINUM COMPONENTS SUCH AS EQUALIZING BEAMS CAN BE DAMAGED WITH PROLONGED EXPOSURE TO SALT, OR TO ACID WHICH IS SOMETIMES USED TO REMOVE CONCRETE. CONTINUED EXPOSURE COULD RESULT IN A FAILURE OF THESE PARTS AND LOSS OF VEHICLE CONTROL, POSSIBLY CAUSING PERSONAL INJURY OR PROPERTY DAMAGE.

ALUMINUM COMPONENTS CAN ALSO BE DAMAGED BY CONTACT WITH HARD OBJECTS WHICH GOUGE THESE PARTS. THESE CONDITIONS COULD RESULT IN A FAILURE OF THESE PARTS WHICH MAY RESULT IN THE LOSS OF VEHICLE CONTROL AND

Figure 1—RTE2 Series Suspension

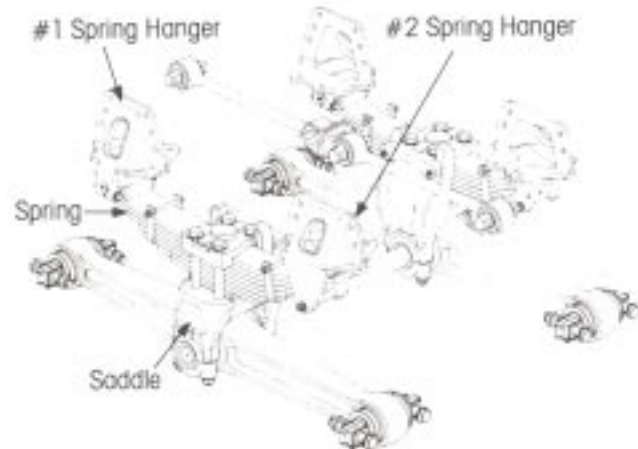
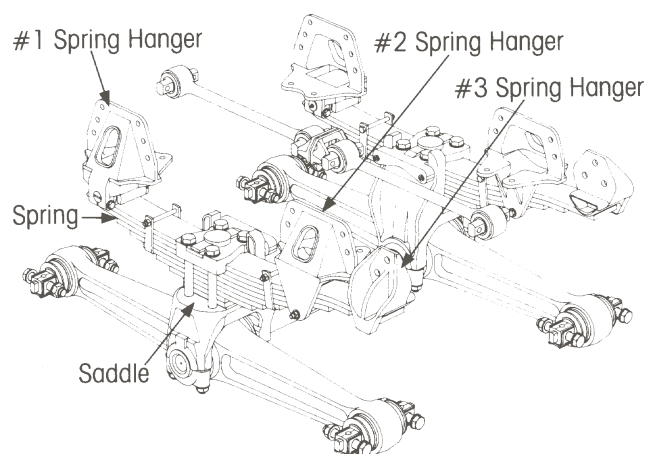

Figure 2—RTE2 Series Suspension



The Boler Company.
Copyright © 1993
Hendrickson Truck
Suspension Systems
All Rights Reserved.

POSSIBLE PERSONAL INJURY OR PROPERTY DAMAGE.
Subject 2 (Continued)
IMPORTANT SAFETY NOTICE

DO NOT MODIFY OR REWORK PARTS. DO NOT USE SUBSTITUTE PARTS. USE OF A MODIFIED OR SUBSTITUTE PART IS NOT RECOMMENDED BECAUSE THE PART MAY NOT MEET HENDRICKSON'S SPECIFICATIONS, WHICH COULD RESULT IN FAILURE OF THE PART, LOSS OF VEHICLE CONTROL, AND POSSIBLE PERSONAL INJURY OR PROPERTY DAMAGE.

DO NOT USE A CUTTING TORCH TO REMOVE ANY ATTACHING FASTENERS. DO NOT USE A CUTTING TORCH TO REMOVE THE EQUALIZING BEAMS FROM THE AXLES OR TO REMOVE THE BUSHINGS FROM THE BEAM CENTERS OR ENDS. ALL HENDRICKSON EQUALIZING BEAMS ARE HEAT TREATED FOR STRENGTH AND SERVICE LIFE. THE USE OF HEAT ON SUSPENSION COMPONENTS WILL ADVERSELY AFFECT THE STRENGTH OF THESE PARTS. A COMPONENT DAMAGED IN THIS MANNER MAY RESULT IN THE LOSS OF VEHICLE CONTROL AND POSSIBLE PERSONAL INJURY OR PROPERTY DAMAGE.

A MECHANIC USING A SERVICE PROCEDURE OR TOOL WHICH HAS NOT BEEN RECOMMENDED BY HENDRICKSON MUST FIRST SATISFY HIMSELF THAT NEITHER HIS SAFETY NOR THE VEHICLE'S SAFETY WILL BE JEOPARDIZED BY THE METHOD OR TOOL SELECTED.

THE USE OF EXCHANGE EQUALIZING BEAMS IS STRICTLY DISCOURAGED UNLESS THE BEAMS WERE ORIGINALLY FROM THE SAME CUSTOMER WHERE THE HISTORY OF THEIR SERVICE IS SPECIFICALLY KNOWN. USING EXCHANGE BEAMS OF UNKNOWN ORIGIN, WHERE TIME IN SERVICE OR APPLICATION AND LOADINGS ARE NOT KNOWN, CAN LEAD TO FAILURE, RESULTING IN THE LOSS OF VEHICLE CONTROL AND POSSIBLE PERSONAL INJURY OR PROPERTY DAMAGE.

Subject 3
DESCRIPTION

The RT2series suspensions (Figure 1) use leaf springs to cushion road shocks. The springs are mounted on saddle assemblies above the equalizing beams and are connected at the front ends to spring hangers with spring eye pins through the spring eyes. The rear ends of the springs have no rigid attachment to the spring hangers and they are free to move forward and backward to

Figure 3—RTE2—Spring Unloaded

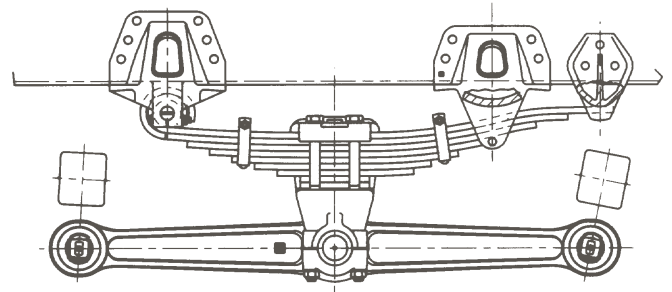
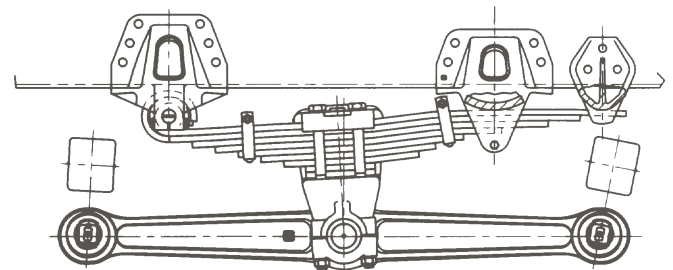

Figure 4—RTE2—Spring Loaded



accommodate spring deflection.

The RTE2 series suspensions (Figure 2) have additional rear spring hangers and use springs with the four top leaves extended through the #2 spring hangers and stepped off to the additional #3 spring hangers. This design provides a two stage spring rate which allows the suspension to provide good empty ride and yet maintain good springing and stability for loaded conditions. To maintain this ride feature, a minimum clearance of 3/8" must be available between the cam surface of the #2 spring hangers and the top of the main leaves in the unloaded condition (see Figures 3 and 4).

All RT2and RTE2 series leaf springs have either a flat washer used with a 5/8" center bolt or a pilot cup forged upward in the main leaf used with a 1/2" center bolt. Either arrangement pilots into a cavity in the spring top pad to ensure the correct positioning of the spring in the saddle assembly.

CAUTION: Do not attempt to use springs from the RU or U series suspensions in the RT2series suspensions. They are not interchangeable because they have different cup designs.

Subject 4 ALIGNMENT

The points controlling alignment are:

The location of the frame hangers on the frame as installed by the vehicle manufacturer.

The location of the beam hangers on the axles as installed by the axle manufacturer or the truck manufacturer.

If your vehicle has the bar pin connector, refer to 17730-190.

Subject 5 PREVENTIVE MAINTENANCE

Lubrication. The RT2/RTE2 series suspensions use bronze, ball indented bushings in the spring eyes. These bushings ride on hardened steel pins which have lubrication channels.

Lubrication should be performed during routine vehicle PM schedules with a good quality chassis lubricant. For severe service operations, the frequency of lubrication should be increased.

The rear of the chassis should be raised to relieve load on the bushings and pins to allow the proper flow of lubricant around the pins and bushings. Continue to lubricate until lubricant comes out both ends of the bushing. If the pin will not accept lubricant, remove the pin and clean the lubrication channels where lubricant may have hardened. **WARNING: Do not use heat as this is a heat treated part.**

#1 Spring Hanger (Double lock bolt design). Check tightening torque lock bolt locknuts. If looseness of this connection has resulted in pin hole wear, replace the hanger.

#1 Spring Hanger (Draw key design). Inspect the pin hole in the outboard leg of the hanger for wear or elongation. Wear at this point requires hanger replacement or premature fracture of the spring hanger pin may occur with possible separation of components and loss of vehicle control.

#2 Spring Hanger. Inspect the cam surface for wear due to high mileage. Also inspect the outside legs for wear which can be caused by worn spring eye bushings. Excessive wear at either point requires hanger replacement.

NOTE: RTE2 series suspensions with extended leaf springs require a minimum gap of 3/8" between the cam surface of the #2 spring hanger and the top of the main leaf in the unloaded condition as shown in Figure 3. If this gap is less than 3/8", the extended leaf portion of the spring will not perform satisfactorily for empty ride.

#3 Spring Hanger. This hanger is used on the RTE2 extended leaf spring series only. Inspect the cam surface for wear. Excessive wear will reduce the gap available at the #2 spring hanger (see note above).

Spring Eye Pin and Bushing. To check for spring eye bushing wear, a block of wood can be placed on the spring and, with a pry bar, attempt to lift the spring hanger and frame as shown in Figure 5. Alternately, and with an empty chassis and brakes applied, attempt to rock the chassis back and forth while observing the spring eye. In either case, if 1/8" or more movement is noted, the bushing and pin should be replaced. This also could indicate a broken spring eye and spring is connected to the spring hanger through the wrapper eye of the second leaf. In this case, the main leaf or complete spring should be replaced immediately.

SAFETY NOTE: USE CAUTION WHEN APPLYING THESE TECHNIQUES SO THAT PERSONAL SAFETY AND VEHICLE SAFETY ARE NOT JEOPARDIZED.

Figure 5

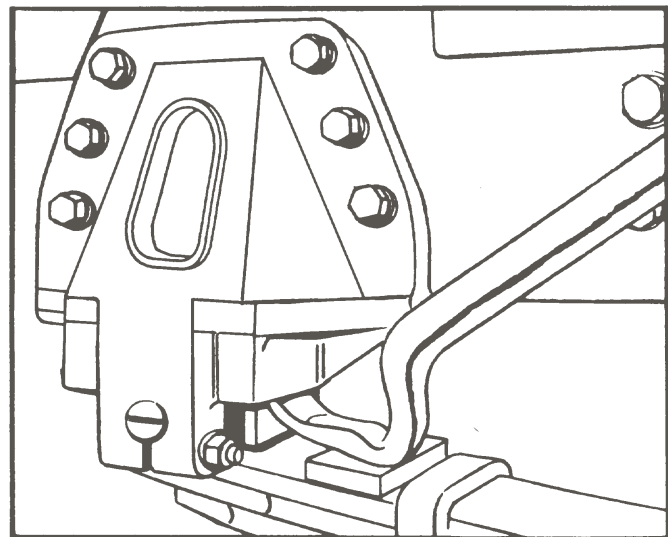



Subject 5 (Continued) PREVENTIVE MAINTENANCE

When replacing the spring eye bushing, the split must be positioned at the top of the spring eye as shown in Figure 6.

Saddle cap fasteners. The locknuts should be tightened as shown in Figure 7 to prevent wear of the beam center bushing into the saddle.

Spring assembly. Inspect all leaves and spring clips for cracks or damage. We recommend that high mileage springs (for your type of operation) with one or more leaves broken below the #2 leaf be replaced with a genuine Hendrickson Truck Suspension Systems spring assembly of the same part number. Main and wrapper leaves are normally available as service replacements. The spring part number is stamped on the spring clips. We also recommend that both springs be replaced to ensure even spring deflection. All Hendrickson Truck Suspension Systems springs are made to rigid specifications and each leaf is shot peened for long life. To assure compatibility and functionality as a suspension system, genuine Hendrickson Suspension springs should be specified.

Figure 6

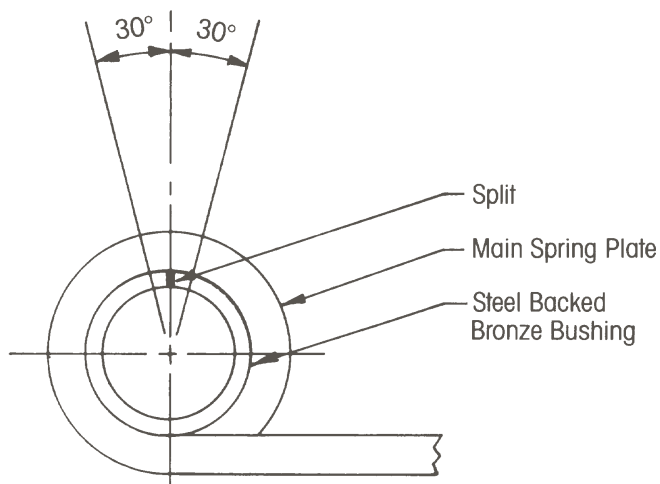
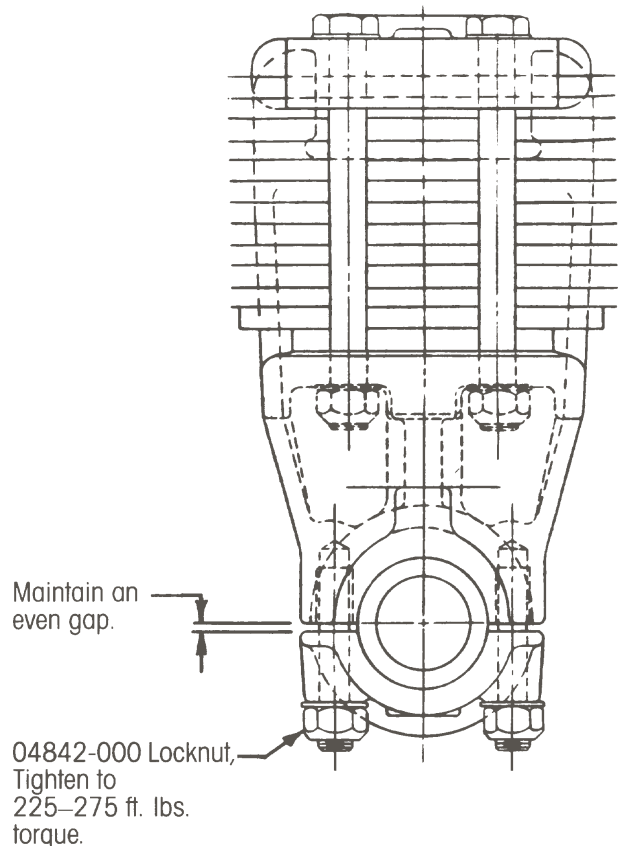

Figure 7



Subject 6 DISASSEMBLY

Experience in servicing the RT2 and RTE2 series suspensions indicates that when a major overhaul is required, the complete tandem unit should be removed from the frame. However, the torque rods, springs, equalizing beams and other components may be removed separately, as may be necessary. (See Technical Publication 17730-190.)

Spring and saddle assemblies. With the equalizing beams and axles rolled out from under the frame, support the spring and saddle assembly on a floor jack as shown in Figure 8. Remove the #1 spring hanger lock bolt(s) and drive out the spring hanger pin as shown in Figure 9. Remove the rebound bolt and spacer from the #2 spring hanger and lower the spring and saddle assembly from the spring hangers. Remove the spring and saddle assembly from the opposite side of the chassis in the same manner, and place them in a work area for disassembly.

Subject 6 (Continued)
DISASSEMBLY

Springs. Loosen the spring top pad set screws, remove the top pad bolts and the top pad, and remove the spring from the saddle.

Spring hangers. Remove the spring hangers from the frame.

Figure 8

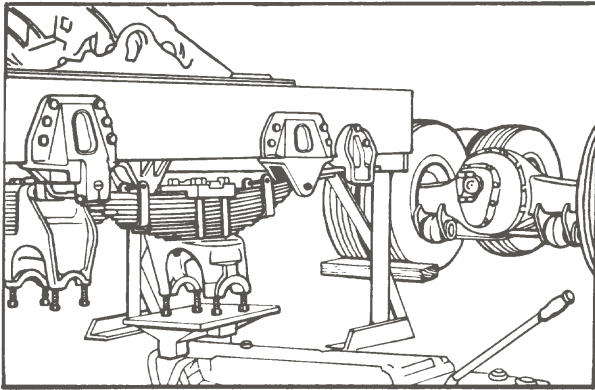
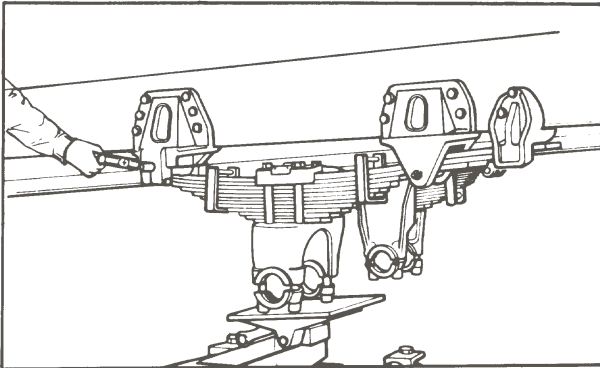

Figure 9



Subject 7
REASSEMBLY

Spring Hangers. Install the new, or removed and inspected spring hangers on the frame. The vehicle manufacturer furnishes the fasteners that attach these parts to the frame. Follow their recommended tightening torque values for these fasteners. Hendrickson recommends grade 8 bolts, grade C locknuts, and flat, plated, hardened washers under the bolts heads and locknuts as shown in Figures 10, 11, and 12.

Figure 10

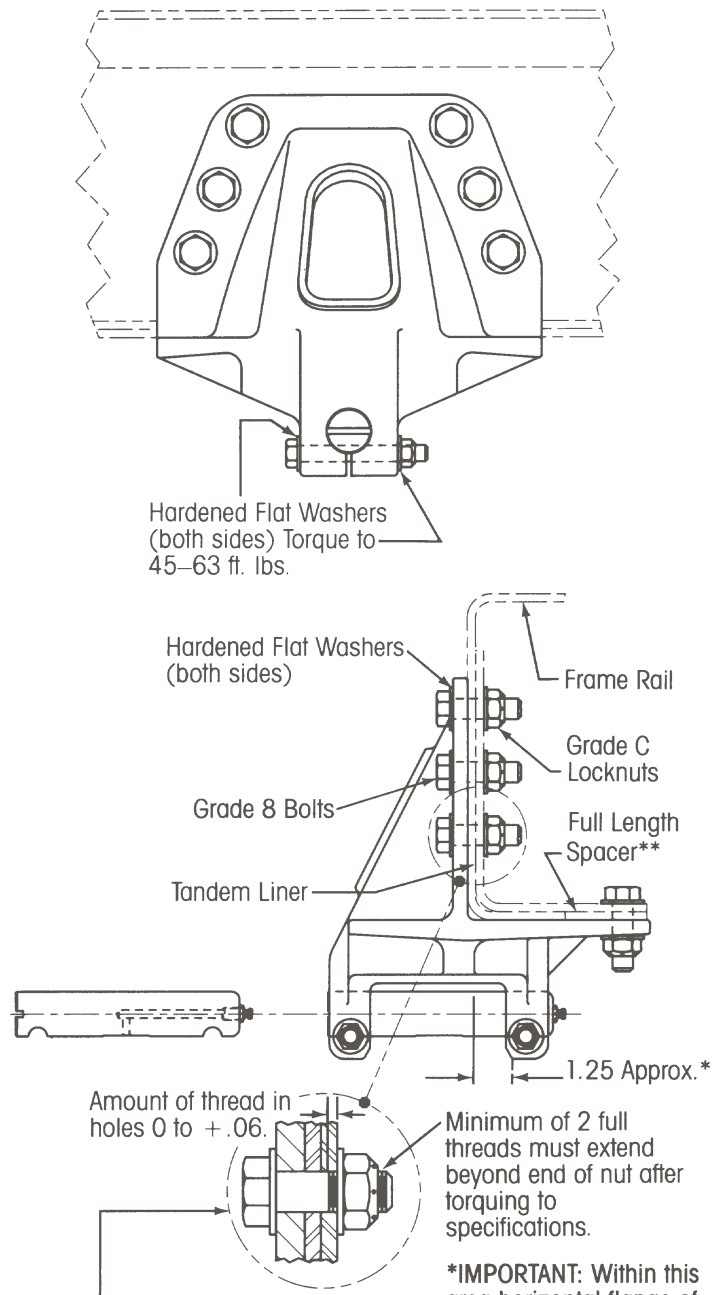

NOTE: Based on size of bolt, applicable tightening torques must be applied as listed in Industrial Fasteners Institute (IFI), Document IFI-101.

***IMPORTANT:** Within this area horizontal flange of spring hanger must fit flush and tight against the bottom horizontal flange of frame rail.

****IMPORTANT:** Thickness of full length spacer must be equal to gap between hanger and frame liner.



Figure 11

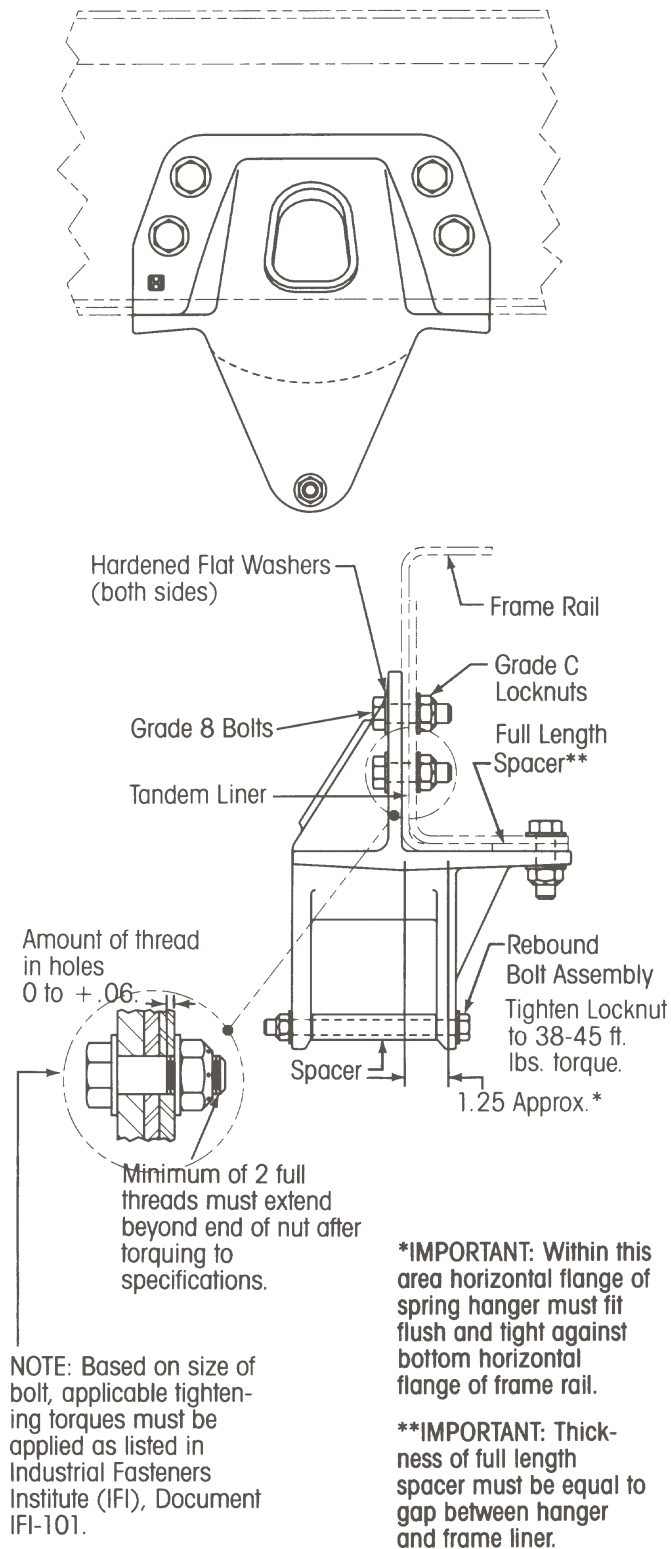
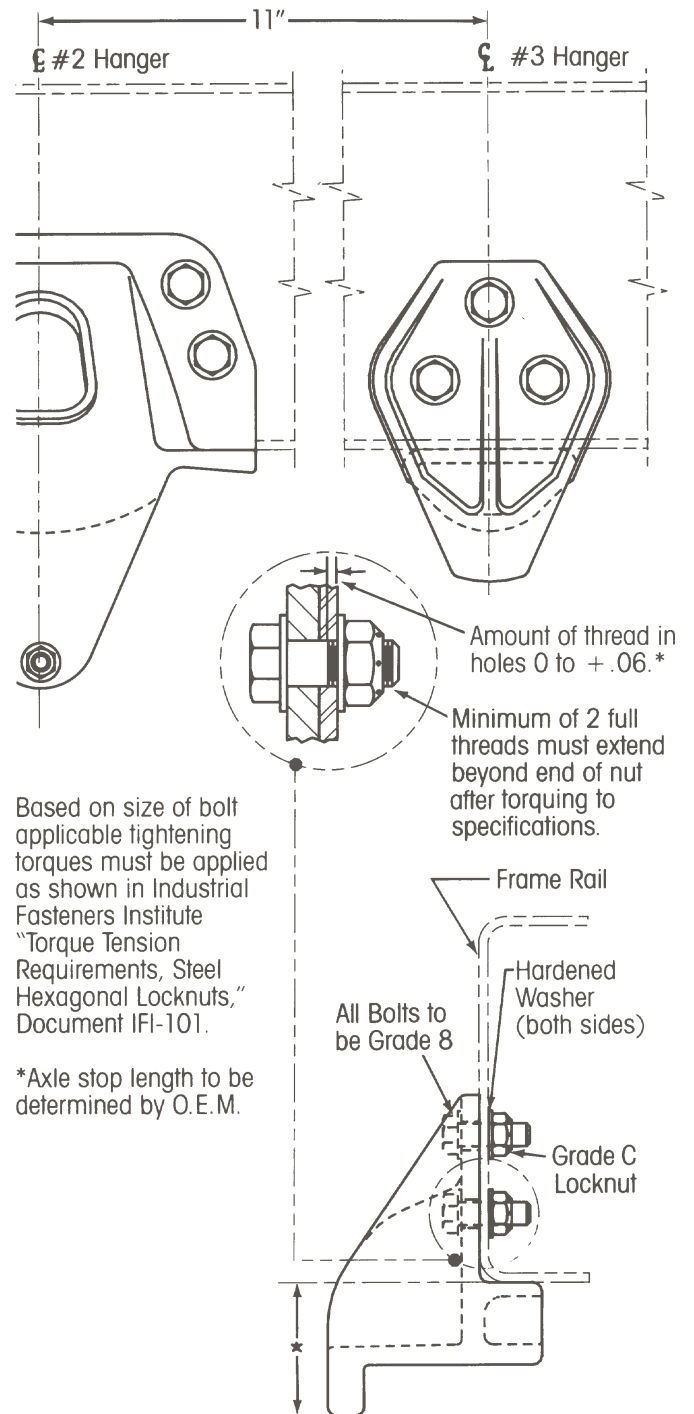

Figure 12

NOTE: Lubricate all threads with SAE 20 oil before assembly.



Subject 7 (Continued)
REASSEMBLY

Springs. Position the new or rebuilt spring assembly on the saddle. A left hand spring and saddle assembly, or right hand spring and saddle assembly can be assembled depending upon way the spring is facing on the saddle. The hole in the spring seat of the saddle is a clearance hole for the spring center bolt. It is not intended to be a pilot hole.

Assemble the top pad between the saddle chair back ears and on top of the main leaf of the spring assembly. The main leaf has either a flat washer or a pilot cup forged upward at the center bolt that pilots into a cavity in the spring top pad. This feature provides the correct alignment of the spring assembly in the saddle.

Assemble the four top pad bolts with washers and locknuts through the top pad and saddle. Snug up the locknuts enough to hold the assembly in place.

Assemble the top pad set screws and evenly tighten as shown in Figure 13.

Evenly tighten the top pad bolt locknuts as shown in Figure 13.

Spring and saddle assemblies. Coat the I.D. of the spring eye bushing with lubricant. Using a roller jack, position the spring and saddle assembly into the #1 and #2 spring hangers. Align the spring eye with the pin hole in the #1 spring hanger. Coat the spring hanger pin with lubricant, and with the slotted end facing outboard, pilot the pin into the outside spring hanger leg, through the spring eye, and into the spring hanger inboard leg.

For double lock bolt #1 spring hangers, rotate the pin using the slot to align the key ways and assemble the lock bolts, washers and locknuts as shown in Figure 10.

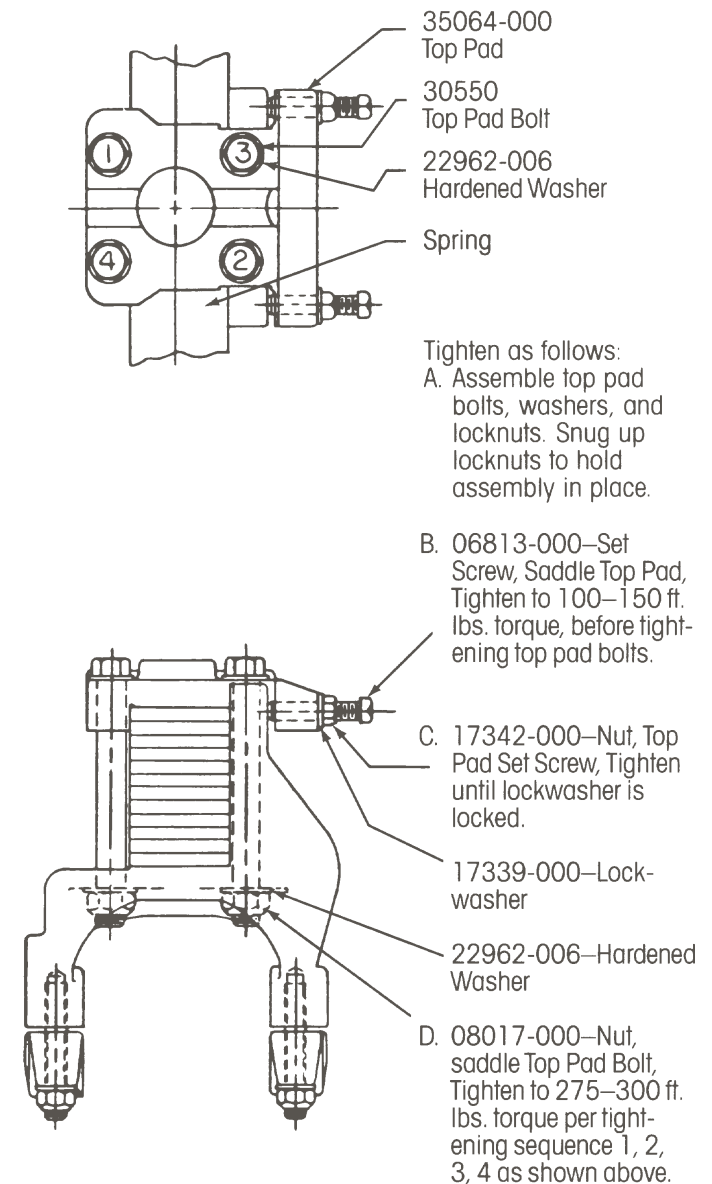
Figure 13



Subject 7 (Continued)
REASSEMBLY

For draw key #1 spring hangers, rotate the pin using the slot to align the key way and assemble the draw key with the flat side up. Fit the flat of the draw key into the pin key way. Drive the draw key with a hammer. Assemble the lock washer and nut as shown in Figure 14. If the draw key is allowed to enter the pin key way on an angle, it will wedge and gall. When locked in this position, it will become loose in a short time and allow the pin to turn and elongate the spring hanger pin hole. This may result in the failure of the pin, spring eye, or spring hanger.

Install lube fitting and pressure lubricate until lubricant appears at both ends of the spring eye bushing.

Assemble the rebound bolt with spacer and locknut through the legs of the #2 spring hanger as shown in Figure 15.

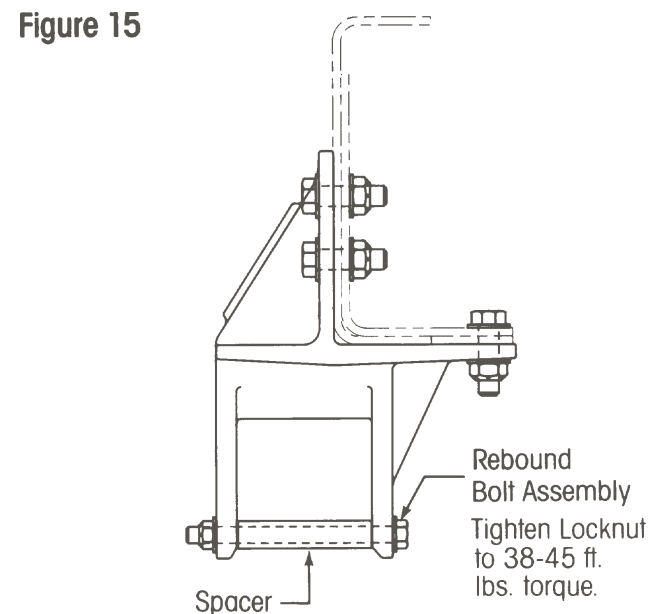
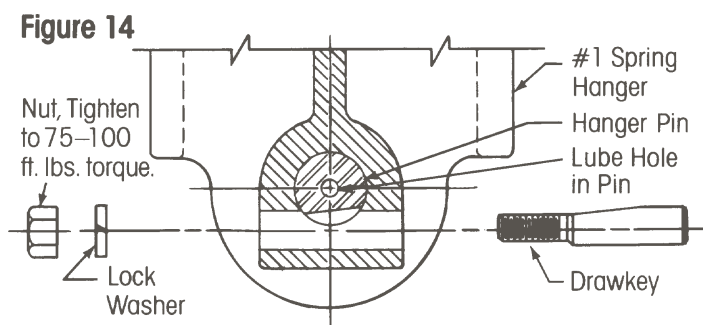

Equalizing beams. Roll the axles with equalizing beams attached under the vehicle as outlined in Technical Publication 17730-190.

With the saddle caps removed, lower the chassis so that the saddles contact the equalizing beam center bushings. Assemble the saddle caps, washers, and locknuts. Evenly tighten the locknuts to prevent distortion of the saddle cap and studs as shown in Figure 16.

NOTE: See Technical Publication 17730-190 for additional information pertaining to equalizing beams, cross tubes, and torque rods.

Figure 16

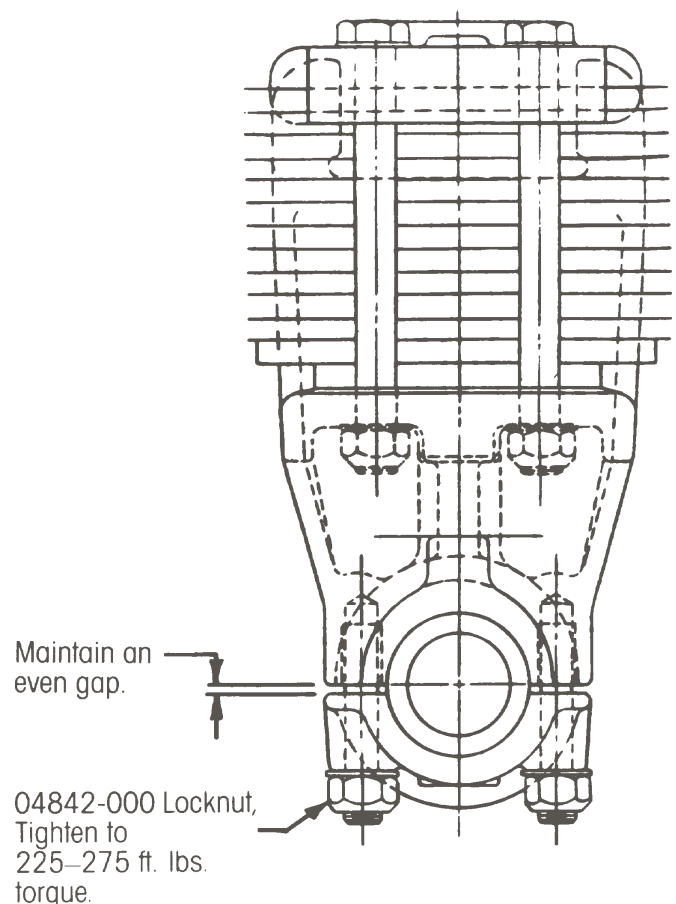



Subject 8
TIGHTENING TORQUE SPECIFICATION CHART

DESCRIPTION	HENDRICKSON PART NO.	THREAD/GRADE	RECOMMENDED TORQUE (FT. LBS.)
Spring Center Bolt Nut	05070-000	1/2-20 UNF-2B Grade 5	65-75
Spring Center Bolt Nut	19114-000	5/8-18 UNF-2B Grade 5	100-125
Spring Pin Draw Key Nut	17351-000	1/2-13 UNC-2B Grade 5	75-100
Spring Pin Double Lock Locknut	49846-000	1/2-13 UNC-2B Grade C	45-63
Top Pad Set Screw	06813-000	3/4-10 UNC-2A Grade 2	100-150
Top Pad Set Screw	19201-003	3/4-10 UNC-2A Grade 5	120-200
Top Pad Bolt Locknut	08017-000	1"- 14 UNS-2B Grade C	275-300
Rebound Bolt Locknut	49846-000	1/2-13 UNC-2B Grade C	38-45
Saddle Cap Stud (340)	07002-000	7/8-14 UNF-2A Grade 5	55-65
Saddle Cap Stud (400+)	06696-000	7/8-14 UNF-2A Grade 5	55-65
Saddle Cap Stud Locknut	04842-000	7/8-14 UNF-2B Grade B	225-275

All threads must be clean and lubricated with SAE 20 oil before assembly to obtain the correct relationship of torque and fastener tension.

To obtain maximum service life from the suspension system, mounting bolts and nuts should be checked at least once a year and tightened to specified torque.



