

H[®] TECHNICAL PROCEDURE AK-201 UNIVERSAL LOAD SCALE KIT

SUBJECT: Operator's Guide

LIT NO: L597

DATE: November 1999

REVISION: B

AK-201 UNIVERSAL LOAD SCALE KIT (ULSK) DESCRIPTION

The AK-201 Universal Load Scale Kit provides an economical and accurate way to determine axle load. The 2½" diameter gage directly indicates the axle load, making it easy to use by the operator. The gage is adjustable to provide greater accuracy and is available in both dry and liquid-filled models. The AK-201 is available with or without a manual dump feature. It has the same footprint and mounting bolt pattern as Hendrickson's existing load scale kits and comes with push-to-connect fittings.

IMPORTANT: A properly calibrated Universal Load Scale Kit is required for maximum accuracy. The liquid models of the AK-201 Universal Load Scale Kit are factory-calibrated. Do not perform field calibration on these models. Proceed to *Operating the AK-201 Universal Load Scale* section. The dry models of the AK-201 Universal Load Scale Kit require calibration.

CALIBRATION PROCEDURE

Prepare the Trailer for Calibration

1. Load the trailer to its maximum legal load (or as close as possible).
2. Locate a drive-on scale that gives reliable weight measurements. Position the trailer on the scale.
3. During calibration, maintain the proper air pressure in the trailer reservoir.

Calibrate the AK-201 ULSK — Dry Models

IMPORTANT: The gage should be in the off position unless calibrating it or when measuring load. If left in the on position while operating the vehicle, the gage will be damaged.

1. Weigh each axle load or combination.
2. Add the weight of all trailer axles. Divide the total weight by the number of trailer axles for the average weight per axle.
3. Rotate the upper ball valve counterclockwise to the GAGE ON position (Figure 1).

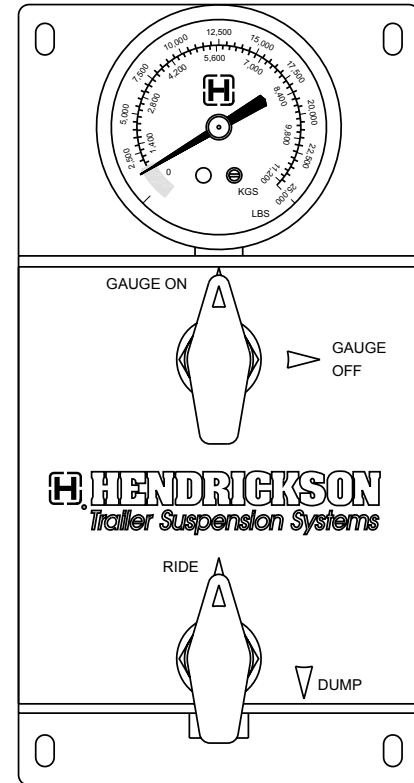

Figure 1. Gage valve to GAUGE ON position
(Kit shown with optional dump feature)

AK-201 ULSK OPERATOR'S GUIDE

4. Read the gage on the AK-201.

IMPORTANT: If the reading is the same as the average weight per axle from step 2; the AK-201 does not need calibration. A reading different than the average weight per axle requires calibration of the AK-201; continue the calibration procedure.

5. Remove the gage's plexiglass face cover by rotating it counter-clockwise.
6. Locate the slotted adjustment pin at the bottom of the gage face. Use a small screwdriver to rotate the adjustment pin until the gage agrees with the average weight per axle.
7. Replace the plexiglass face cover by rotating it clockwise on the gage. Firmly secure the face cover.
8. Return the upper ball valve clockwise to the GAGE OFF position (Figure 2).

OPERATING THE AK-201 UNIVERSAL LOAD SCALE (DETERMINE THE PER-AXLE LOAD)

IMPORTANT: The gage should be in the off position unless calibrating it or when measuring load. If left in the on position while operating the vehicle, the gage will be damaged.

1. Ensure the trailer is at the design ride height.
2. Rotate the upper ball valve counterclockwise to the GAGE ON position.
3. Read the gage for the per-axle load. Multiply the per-axle load by the number of trailer axles for the total trailer load.

NOTE: Kits using the liquid-filled gage read in psi. To determine the axle load for a given pressure, use a pressure versus load conversion table for the suspension model or determine the conversion by using a certified scale.

4. Return the upper ball valve to the GAGE OFF position.

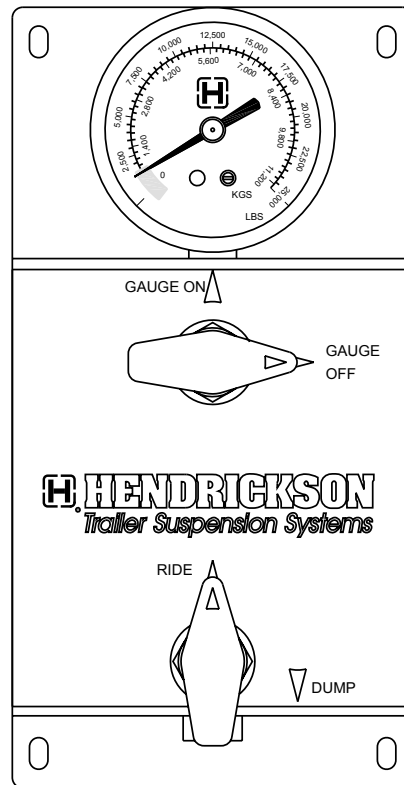

Figure 2. Gauge valve to GAGE OFF position

**OPERATING THE MANUAL DUMP FEATURE
(AK-201-1 THROUGH AK-201-12 ONLY)**

Dump the suspension

1. Rotate the lower ball valve clockwise to the DUMP position (Figure 3).

IMPORTANT: Air should immediately flow out the exhaust port at the bottom of AK-201, which will cause the suspension to lower down and ride on the air spring bumpers.

Return the suspension to ride height

⚠ CAUTION: DO NOT OPERATE the vehicle for prolonged periods of time when the suspension is riding on the air spring bumper. Damage may occur to the air suspension system.

1. Rotate the lower ball valve counterclockwise to the RIDE position and allow the air system to fully charge (Figure 2).

OPTIONAL AK-201 ENCLOSURE

An optional enclosure for the Universal Load Scale Kit is available. To order the enclosure separately ask for AK-201-BX (Figure 4).

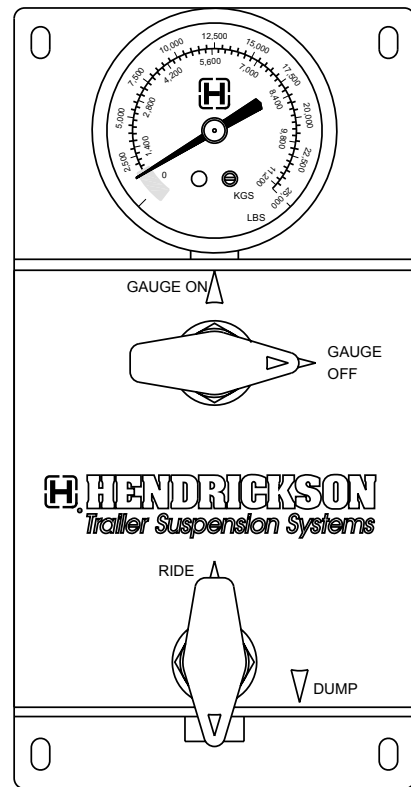

Figure 3. Ride valve to manual DUMP position

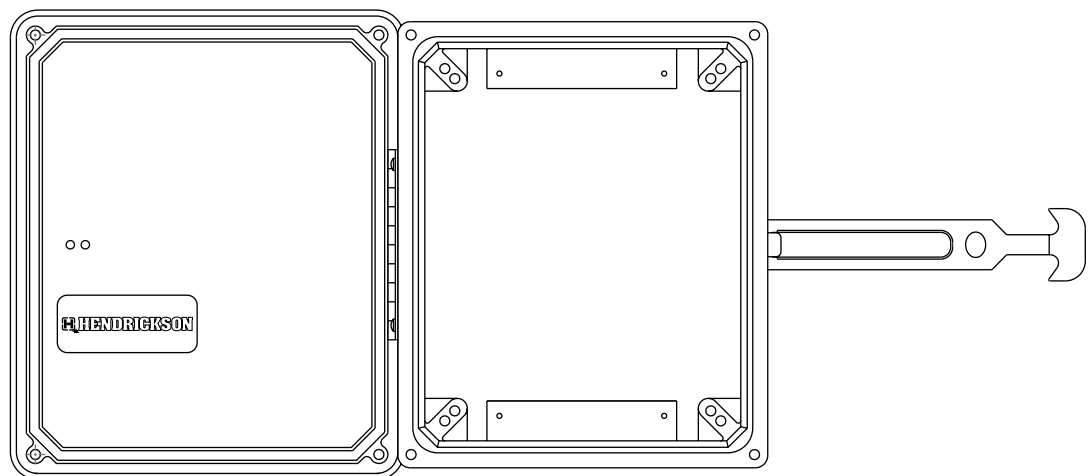
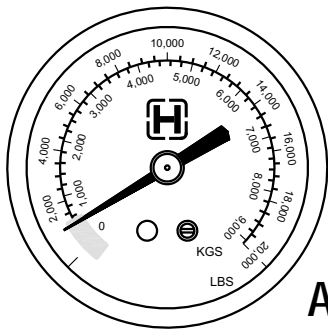
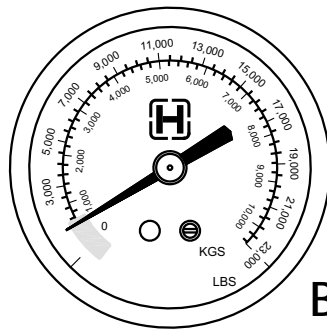

Figure 4. Inside view of AK-201-BX, enclosure for Universal Load Scale Kit

AK-201 ULSK OPERATOR'S GUIDE



A



B

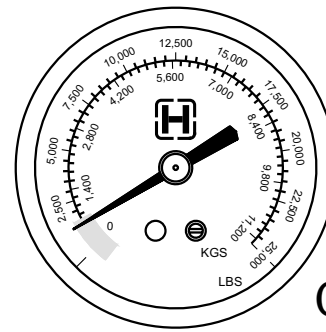

C

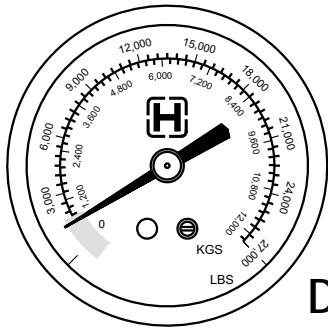

D

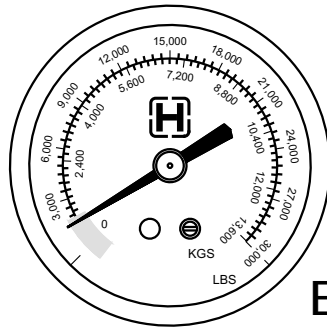

E

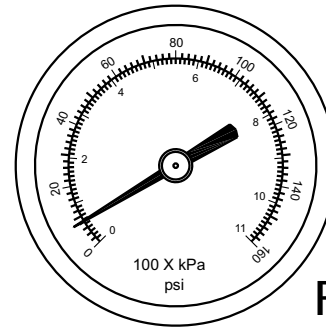

F

AK-201 APPLICATION GUIDE

SUSPENSION MODEL	GAGE TYPE	RATED LOAD/AXLE (LBS)	GAGE RANGE	GAGE	W/DUMP (AK-201-#)		W/O DUMP (AK-201-#)	
					3/8"	1/4"	3/8"	1/4"
HKA180	Dry	20,000	0 — 25,000	C	-5	-6	-25	-26
HK190T	Dry	20,000	0 — 23,000	B	-3	-4	-23	-24
HT190	Dry	19,000	0 — 23,000	B	-3	-4	-23	-24
HT190T	Dry	20,000	0 — 20,000	A	-1	-2	-21	-22
HT190U	Dry	20,000	0 — 27,000	D	-7	-8	-27	-28
HKA200	Dry	23,000	0 — 25,000	C	-5	-6	-25	-26
AA230	Dry	23,000	0 — 25,000	C	-5	-6	-25	-26
HK230T	Dry	23,000	0 — 23,000	B	-3	-4	-23	-24
HT230	Dry	23,000	0 — 23,000	B	-3	-4	-23	-24
AA250	Dry	25,000	0 — 27,000	D	-7	-8	-27	-28
HT250U	Dry	25,000	0 — 25,000	C	-5	-6	-25	-26
HT250US	Dry	25,000	0 — 30,000	E	-9	-10	-29	-30
HT300	Dry	30,000	0 — 30,000	E	-9	-10	-29	-30
HT300U	Dry	30,000	0 — 30,000	E	-9	-10	-29	-30
T-6-068	Dry	25,000	0 — 25,000	C	-5	-6	-25	-26
T-6-252	Dry	25,000	0 — 27,000	D	-7	-8	-27	-28
T-RL	Dry	25,000	0 — 30,000	E	-9	-10	-29	-30
AA230L	Dry	23,000	0 — 23,000	B	-3	-4	-23	-24
AA250L	Dry	25,000	0 — 25,000	C	-5	-6	-25	-26
All Models	Liquid	—	0 — 160 psi	F	-11	-12	-31	-32

HENDRICKSON
Vehicle Control Systems

2070 Industrial Place SE • Canton, Ohio 44707-2600 USA
 Phone (330) 456-7288 • Fax (330) 456-0105

Information contained in this literature was accurate at the time of publication. Product changes may have been made after the copyright date that are not reflected.

L597 Rev B Nov 1999 Printed in United States of America.

www.hendrickson-intl.com

The Boler Company.
 Copyright © 1999
 Hendrickson Trailer
 Suspension Systems
 All Rights Reserved