

H TECHNICAL PROCEDURE INTRAAX® SUSPENSION SYSTEMS

SUBJECT: Shock Mount Replacement Procedures

LIT NO: L724 (Supersedes AM11 Rev B and L594 Rev C)

DATE: December 1999

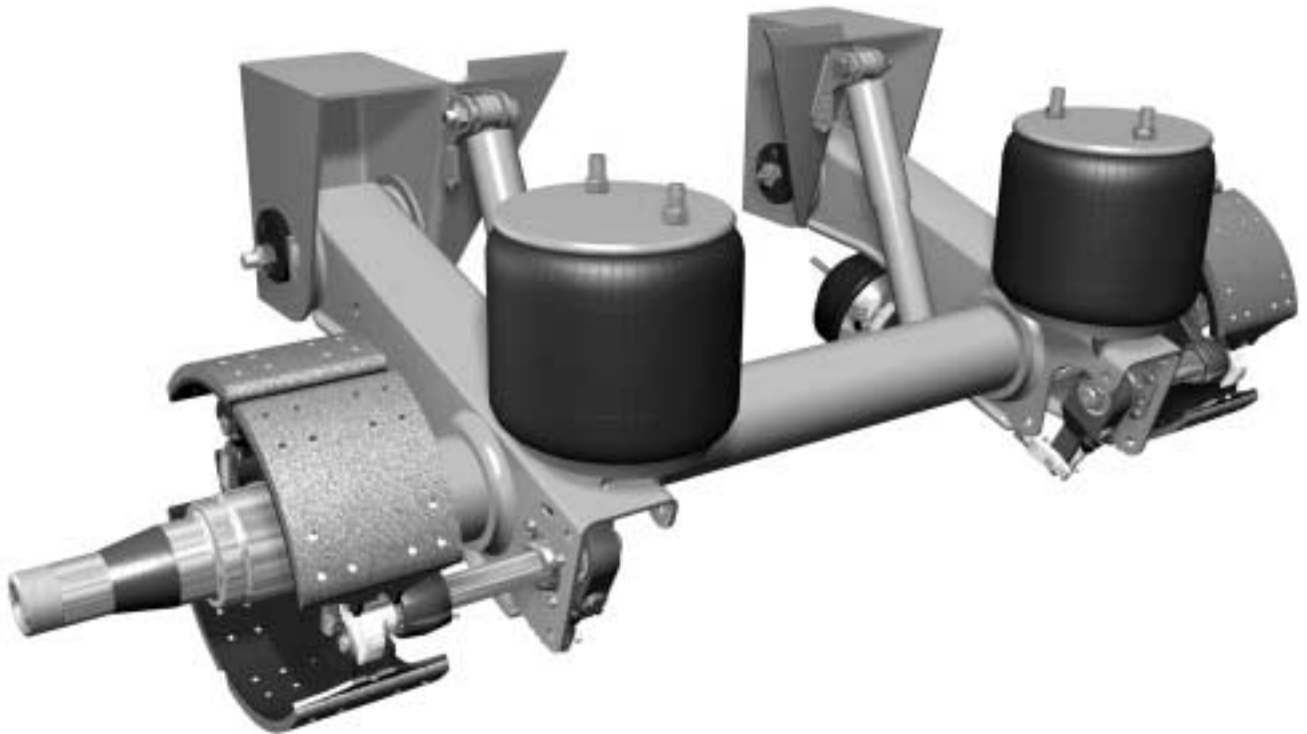

TABLE OF CONTENTS

PREPARATION FOR PROCEDURES

Important Information	2
Model Identification	2

REVISION B PROCEDURES

Undamaged Thread	3
Damaged Thread	3

REVISION C PROCEDURES

Undamaged Thread	4
Damaged Thread	4

APPENDIX

Bolt Replacement Kit for Revisions B and C . . .	6
Revision B Suspensions	6
Revision C Suspensions	7

For The Road Ahead

H HENDRICKSON

INTRAAX® SHOCK MOUNT REPLACEMENT PROCEDURES

PREPARATION FOR PROCEDURES IMPORTANT INFORMATION

⚠ **WARNING:** CHOCK OR BLOCK THE WHEELS ON THE TRAILER TO PREVENT MOVEMENT WHILE WORKING ON THE SUSPENSION OR BRAKE SYSTEM. FAILURE TO BLOCK THE TRAILER MAY LEAD TO SERIOUS INJURY OR DEATH.

⚠ **WARNING:** DO NOT ALLOW THE BRAKE CHAMBER TO HANG FROM THE AIR HOSE WHEN DOING THESE PROCEDURES. IF THE AIR HOSE IS CUT OR SEVERED, PERSONAL INJURY OR COMPONENT DAMAGE MAY OCCUR.

IMPORTANT: Before removing the shock absorbers, read the instructions provided with the new shock absorber. Verify that the part numbers on the new and the old shock absorbers match. Ensure the new parts are correct before removing the old shock absorbers.

1. Refer to the parts list on page 6 for the parts included in kit number S-24021.
2. For torque specifications, refer to the table on page 6.
3. For all procedures in this technical publication, park the trailer on a clean, dry surface. Chock the wheels.

MODEL IDENTIFICATION

1. Before continuing with this publication, you must determine the type of INTRAAX® model — AA230TB, AA250TB, AA230TC, or AA250TC.

IMPORTANT: The model number is on the suspension identification tag, which is located on the inboard side of the suspension beam. The "B" or "C" (the second letter after AA230 or AA250) in the model number indicates the suspension is a Revision B or Revision C (Figure 1).

2. If the suspension is an INTRAAX Revision B, use the instructions after this step. If the suspension is an INTRAAX Revision C, use the **REVISION C PROCEDURE** on page 4.

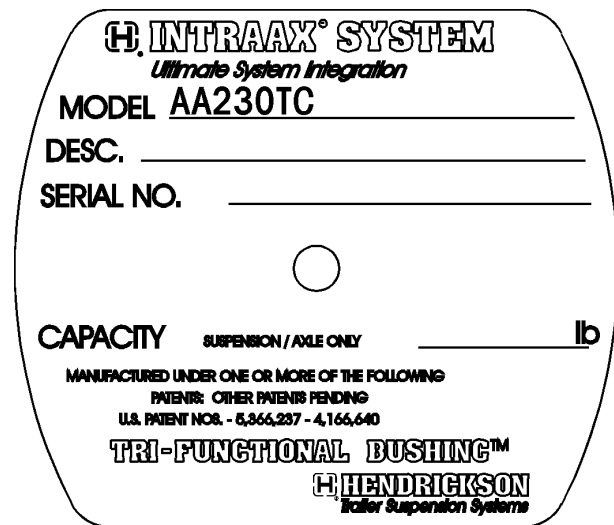

Figure 1. INTRAAX identification tag

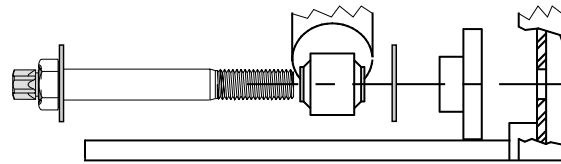

Figure 2. Assemble the shock mounting components

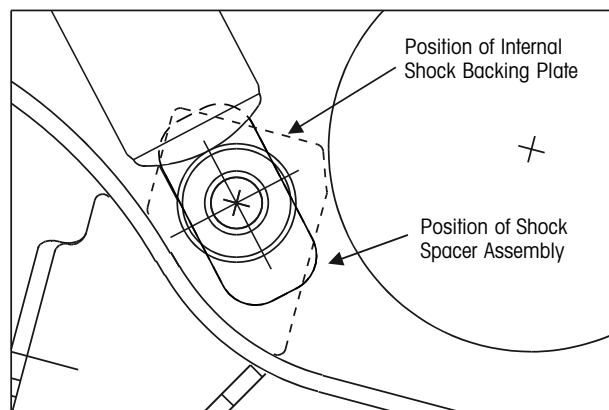

Figure 3. Properly position the shock spacer

INTRAAX REVISION "B" PROCEDURES UNDAMAGED THREAD PROCEDURE

1. Spray a penetrant type fluid on the lower shock absorber mounting bolt where it enters the suspension beam. Allow the penetrant to be absorbed for several minutes before attempting to loosen the bolts.
2. Use a 1¹/₈-inch wrench or socket to remove the lower shock absorber mounting bolt, flat washer, and spacer from between the shock absorber and the suspension beam; discard these parts.

IMPORTANT: When removing the lower shock bolt, be careful not to strip the nut that is located on the inside of the suspension beam.

3. Visually check the threads on the nut inside the suspension beam to ensure they are in good condition. If the nut is defective, go to REVISION "B" DAMAGED THREAD PROCEDURE.
4. Do not apply lubricants or Never-Seize to the threads of the shock mounting bolt.
5. Insert the shear-type shock bolt through the hardened washer, shock, hardened washer, spacer block and into the hole in the suspension beam (Figure 2).

IMPORTANT: Check the spacer block for proper installation. The spacer must be positioned properly on the beam for maximum effectiveness (Figure 3).

6. Use an E-20 ³/₄-inch drive socket to tighten the shock bolt until the shear head separates at 210-235 ft-lbs.

REVISION "B" DAMAGED THREAD PROCEDURE

1. If the nut in the suspension beam is damaged, install a new mounting hardware kit in the beam.
2. Release the trailer parking brakes of the affected axle by caging the brake chambers according to the brake chamber manufacturer's procedure.

⚠ WARNING: YOU MUST CHOCK OR BLOCK THE WHEELS ON THE TRAILER TO PREVENT MOVEMENT WHILE WORKING ON THE SUSPENSION OR BRAKE SYSTEM. FAILURE TO PROPERLY BLOCK THE TRAILER COULD LEAD TO SERIOUS INJURY OR DEATH.

3. Remove the slack adjuster.
4. Use a ¹⁵/₁₆-inch wrench or socket to loosen and remove the nuts that attach the brake chamber to the mounting bracket. Remove the brake chamber from the mounting bracket. Store brake chamber out of the way for this procedure.

⚠ WARNING: DO NOT ALLOW THE BRAKE CHAMBER TO HANG FROM THE AIR HOSE DURING THIS PROCEDURE. IF THE LINE SHOULD BE CUT OR SEVERED COMPONENT DAMAGE OR PERSONAL INJURY MAY OCCUR.

5. Use a hammer with a punch, or chisel, to strike the defective mounting pieces until the tack welds break loose. Replace parts as necessary.
6. If tack-weld slag remains on the beam, remove it before installing the new parts.
7. Hold the new backing plate, spacer and nut up to the inside of the beam at the shock mounting hole.
8. Install the shear-type shock bolt and external hardware per step #5 in the previous procedure (Figure 5, page 6).

IMPORTANT: Tack welding the backing plate to the suspension beam is not required. It will be necessary to hold the nut with a 1¹/₈-inch wrench while tightening the mounting bolt.

9. Use an E-20 ³/₄-inch drive socket to tighten the shock bolt until the shear head separates at 210-235 ft-lbs.
10. Mount the brake chamber on the mounting bracket and torque the bolts to 100-110 ft-lbs.

INTRAAX® SHOCK MOUNT REPLACEMENT PROCEDURES

11. Attach brake chamber rod clevis to slack adjuster with the clevis pin. Install a new cotter pin in the clevis pin.
12. Release and remove the caging tool from the brake chamber; follow the brake chamber manufacturer's procedure.
13. Visually check all components for tightened fasteners (Figure 4).

INTRAAX REVISION "C" PROCEDURES UNDAMAGED THREAD PROCEDURES

1. Visually check the threads on the nut inside the suspension beam to ensure they are in good condition. If the nut is defective, go to the REVISION "C" DAMAGED THREAD PROCEDURE.

IMPORTANT: If the nut is missing, contact Hendrickson Trailer Suspension Systems Technical Service at (330) 456-7288 Monday through Friday 8 a.m. to 5 p.m. Eastern Time.

2. Do not apply lubricants or Never-Seize to the threads of the shock mounting bolt.
3. Insert the shock bolt through the hardened washer, shock, hardened washer, spacer block and into the hole in the suspension beam (Figure 6, page 7).

IMPORTANT: Ensure spacer block is positioned flush with beam. Spacer must be positioned properly on the beam for maximum effectiveness.

4. Torque the shock mounting bolt to 210-235 ft-lbs.

REVISION "C" DAMAGED THREAD PROCEDURE

1. If the nut in the suspension beam is damaged, it will be necessary to install a new mounting hardware kit in the beam.
2. Release the trailer parking brakes of the affected axle by caging the brake chamber using the brake chamber manufacturer's procedure.

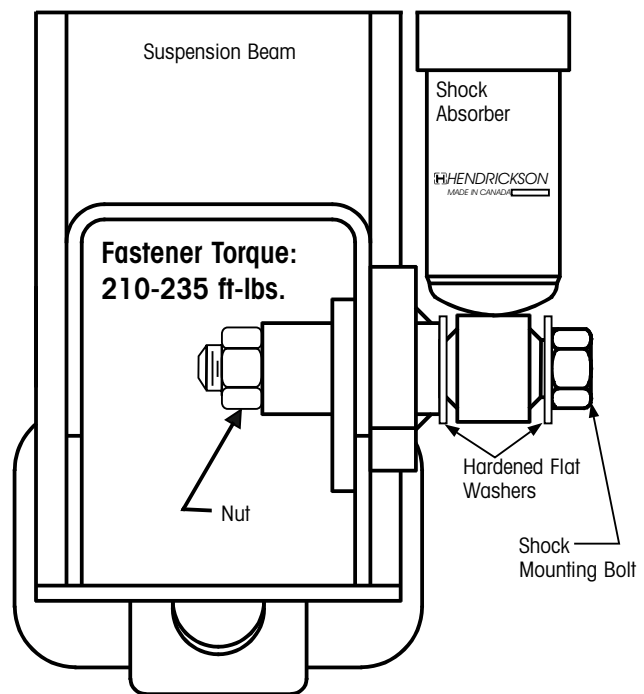

Figure 4. Visually check components

⚠ WARNING: YOU MUST CHOCK OR BLOCK THE WHEELS ON THE TRAILER TO PREVENT MOVEMENT WHILE WORKING ON THE SUSPENSION OR BRAKE SYSTEM. FAILURE TO PROPERLY BLOCK THE TRAILER COULD LEAD TO SERIOUS INJURY OR DEATH.

3. Remove the slack adjuster.
4. Using a $1\frac{5}{16}$ -inch wrench or socket, loosen and remove the nuts that attach the brake chamber to the mounting bracket. Remove brake chamber from mounting bracket.
5. Store the brake chamber out of the way during this procedure.

⚠ WARNING: DO NOT ALLOW THE BRAKE CHAMBER TO HANG FROM THE AIR HOSE DURING THIS PROCEDURE. IF THE LINE SHOULD BE CUT OR SEVERED COMPONENT DAMAGE OR PERSONAL INJURY MAY OCCUR.

6. Remove the lower shock mounting threads within the suspension beam by drilling with a $\frac{3}{4}$ -inch drill bit.
7. Insert a new prevailing torque nut through the rear of the suspension beam and position it over the newly drilled $\frac{3}{4}$ -inch hole.
8. Insert the shear-type shock bolt through the flat washer, shock, flat washer and spacer, through the $\frac{3}{4}$ -inch hole and begin threading onto the nut (Figure 7, page 7).
9. Hold the nut with $1\frac{1}{8}$ -inch wrench.
10. Use an E-20 $\frac{3}{4}$ -inch drive socket to tighten the shock bolt until the shear head separates at 210-235 ft-lbs.
11. Mount the brake chamber on the mounting bracket and torque the bolts to 100-110 ft-lbs.
12. Reinstall the slack adjuster.
13. Attach brake chamber rod clevis to the slack adjuster with the clevis pin. Install new cotter pin in clevis pin.
14. Release and remove the caging tool from the brake chamber; follow the brake chamber manufacturer's procedure.
15. Visually check all components to ensure fasteners are tight.

INTRAAX® SHOCK MOUNT REPLACEMENT PROCEDURES

BOLT REPLACEMENT PARTS KIT (P/N S-24021)*			
PART NUMBER	PART DESCRIPTION	QUANTITY	REVISION(S)
A-22577	Hardened Flat Washers	2	B and C
B-24058-1	3/4"-10 x 5 3/4" Lower Shock Mount Shear-Type Bolt	1	B and C
B-23784	Shock Spacer Assembly	1	B and C
SA-8900-3	3/4" -10 Lock Nut	2	B and C
SA-1000-47	3/4"-10 x 3 1/2" Upper Shock Mount Bolt	1	B and C
A-20871	Shock Backing Plate	1	B only
A-20913	Shock Spacer	1	B only
SA-10200-1	3/4"-16 x 4 1/2" Lower Shock Mount Bolt	1	C only

*This kit (S-24021) contains parts for use in all the procedures described in this publication for the revision B and C INTRAAX suspensions. You may not need all parts to complete your replacement procedure. You may discard these extra parts after completing the replacement.

TORQUE SPECIFICATIONS		
PART	FT-LBS.	N•M
Brake Chamber Fastener	100-110	136-149
Hex Head Cap Screw	210-235	285-319

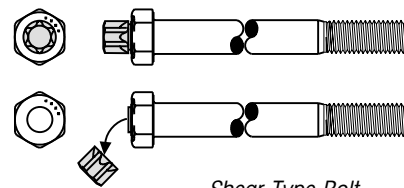

Shear-Type Bolt

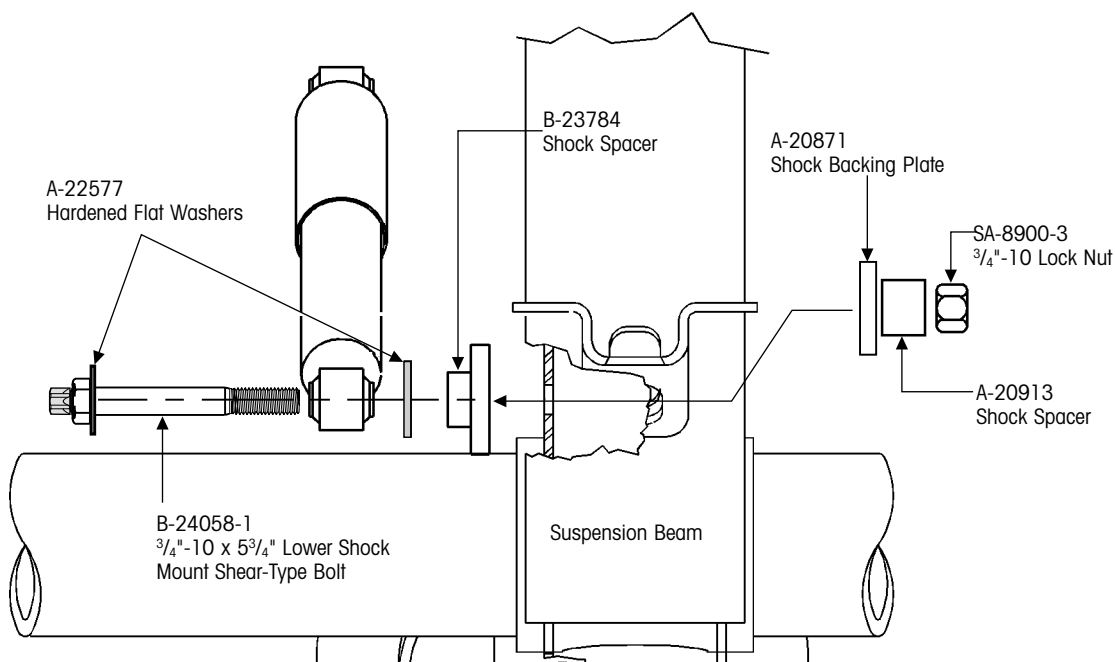

Figure 5. AA230/AA250 Rev. B (Damaged Thread)

INTRAAX® SHOCK MOUNT REPLACEMENT PROCEDURES

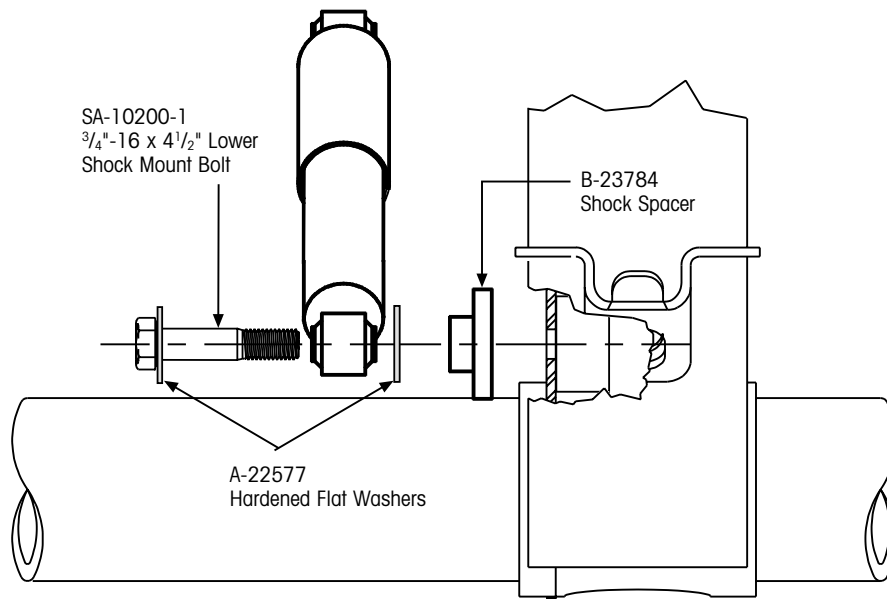

Figure 6. AA230/AA250 Rev. C (Undamaged Thread)

IMPORTANT: Tighten shock mounting fasteners to a torque of 210-235 ft-lbs. (285-319 N•m).

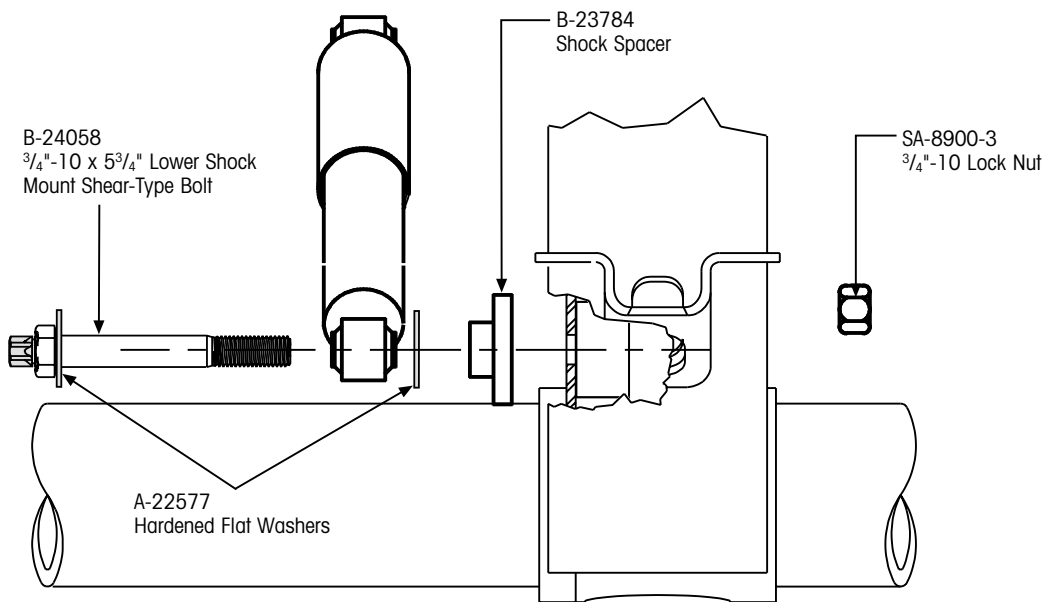

Figure 7. AA230/AA250 Rev. C (Damaged Thread)

Trailer Suspension Systems
2070 Industrial Place SE
Canton, OH 44707-2600 USA
800.455.0043
330.489.0045
Fax 800.696.4416



Trailer Suspension Systems
250 Chrysler Drive, Unit #3
Brampton, ON L6S 6B6 Canada
905.789.1030
Fax 905.789.1033