



# **TECHNICAL PROCEDURE** COMFORT AIR®

**SUBJECT:** Service Instructions

**LIT NO:** 17730-246

**DATE:** December 2007 **REVISION:** B

## TABLE OF CONTENTS

<b>Section 1</b>	<b>Introduction</b> . . . . .	2	<b>Section 8</b>	<b>Component Replacement</b>	
<b>Section 2</b>	<b>Product Description</b> . . . . .	3		Frame Hanger . . . . .	18
<b>Section 3</b>	<b>Important Safety Notice</b> . . . . .	4		Main Support Member Assembly . . . . .	19
<b>Section 4</b>	<b>Parts Lists</b> . . . . .	8		Main Support Member Assembly Pivot Bushing . . . . .	21
<b>Section 5</b>	<b>Special Tools</b> . . . . .	10		Spring Seat . . . . .	23
<b>Section 6</b>	<b>Preventive Maintenance</b>			Bottom Cap . . . . .	25
	Component Inspection . . . . .	11		Air Spring . . . . .	26
	Main Support Member Bushings . . . . .	12		Cross Channel . . . . .	26
	U-bolt Locknuts . . . . .	12		Shock Absorber . . . . .	27
	Shock Absorber . . . . .	13		Upper Shock Bracket . . . . .	28
	Transverse Torque Rods . . . . .	14		Lower Shock Bracket . . . . .	28
<b>Section 7</b>	<b>Alignment &amp; Adjustments</b>			Height Control Valve . . . . .	29
	Ride Height Setting . . . . .	15	<b>Section 9</b>	<b>Plumbing Diagram</b> . . . . .	32
	Alignment . . . . .	16	<b>Section 10</b>	<b>Troubleshooting Guide</b> . . . . .	33
			<b>Section 11</b>	<b>Torque Specifications</b> . . . . .	34

## SECTION 1

# Introduction

This publication is intended to acquaint and assist maintenance personnel in the preventive maintenance, service, repair and rebuild of the COMFORT AIR® suspension system.

---

**NOTE**

Use only Genuine  Hendrickson parts for servicing this suspension system.

It is important to read and understand the entire Technical Procedure publication prior to performing any maintenance, service, repair, or rebuild of this product. The information in this publication contains parts lists, safety information, product specifications, features, proper maintenance, service, repair and rebuild instructions for the COMFORT AIR suspension.

Hendrickson reserves the right to make changes and improvements to its products and publications at any time. Contact Hendrickson Tech Services at 630-910-2800 or email [techservices@hendrickson-intl.com](mailto:techservices@hendrickson-intl.com) for information on the latest version of this manual.

**The latest revision of this publication is also available online at [www.hendrickson-intl.com](http://www.hendrickson-intl.com).**

## SECTION 2

# Product Description

The COMFORT AIR rear suspension system, based on Hendrickson's proven HAS technology, is designed for the needs of buses, motor homes, and ambulances. The new system combines superior ride and handling with enhanced equipment protection.

- **Frame hanger** — Wide footprint distributes load over a larger area for reduced frame stress.
- **QUIK-ALIGN®** — Fast and easy alignment without shims, see Figure 2-1.
- **Main support member** — Extended-length generates lower spring rate for optimized roll stiffness providing a more comfortable and compliant ride. It also provides neutral roll steer for better handling.
- **Shock absorbers** — Tuned for optimum damping characteristics to provide maximum driving comfort.
- **Air springs** — Adjust to changing load conditions to deliver superior ride quality.
- **ULTRA ROD®** — Lightweight and durable torque rod. The ULTRA ROD is an integral component of the COMFORT AIR suspension that enhances handling during cornering and helps maintain lateral axle position.
- **Height control valve** — Maintains precise ride height control through changing road surfaces, load, and driving conditions.

**COMFORT AIR** is available in suspension capacities up to 23,000 pounds, and in ride heights of 8.5" and 10.5". The suspension weighs 487 pounds and includes the frame hanger brackets, main support member assembly, axle clamp group, air springs, shock absorbers, cross channel, upper and lower shock brackets, ULTRA ROD transverse torque rod and frame bracket, and height control system.

**FIGURE 2-1**

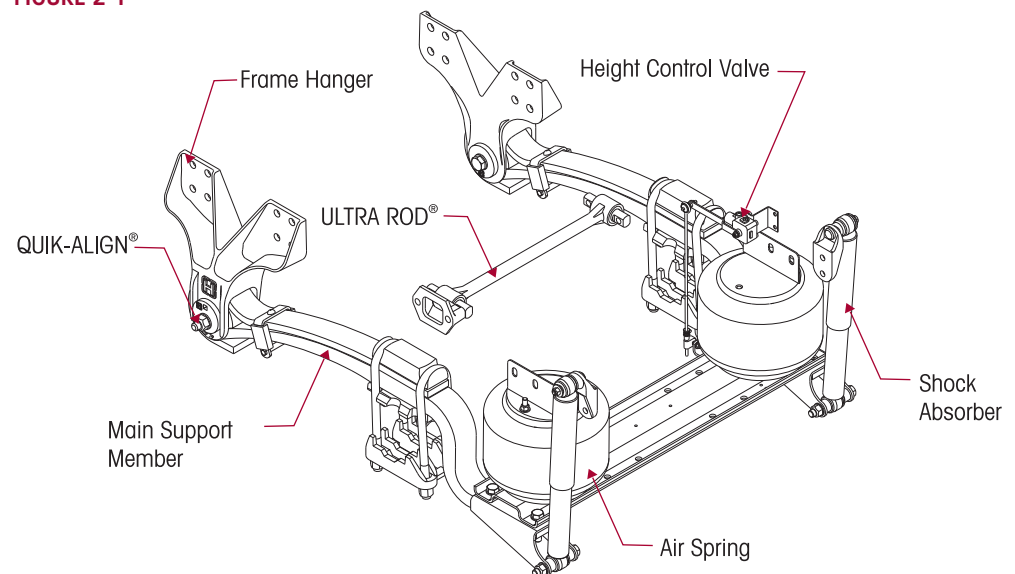

## SECTION 3

## Important Safety Notice

Proper maintenance, service and repair are important to the reliable operation of the suspension. The procedures recommended by Hendrickson and described in this technical publication are methods of performing such maintenance, service and repair.

The warnings and cautions should be read carefully to help prevent personal injury and to assure that proper methods are used. Improper maintenance, service or repair may damage the vehicle, cause personal injury, render the vehicle unsafe in operation, or void the manufacturer's warranty.

Failure to follow the safety precautions in this manual can result in personal injury and/or property damage. Carefully read and understand all safety related information within this publication, on all decals and in all such materials provided by the vehicle manufacturer before conducting any maintenance, service or repair.

**EXPLANATION OF SIGNAL WORDS**

Hazard "Signal Words" (Danger-Warning-Caution) appear in various locations throughout this publication. Information accented by one of these signal words must be observed to help minimize the risk of personal injury to service personnel, or possibility of improper service methods which may damage the vehicle or render it unsafe.



This is the safety alert symbol. It is used to alert you to potential personal injury hazards. Obey all safety messages that follow this symbol to avoid possible injury or death.

Additional 'Notes' or 'Service Hints' are utilized to emphasize areas of procedural importance and provide suggestions for ease of repair. The following definitions indicate the use of these signal words as they appear throughout the publication.



INDICATES AN IMMINENTLY HAZARDOUS SITUATION, WHICH, IF NOT AVOIDED, WILL RESULT IN SERIOUS INJURY OR DEATH



INDICATES A POTENTIAL HAZARDOUS SITUATION WHICH, IF NOT AVOIDED, CAN RESULT IN DEATH OR SERIOUS INJURY



INDICATES A POTENTIAL HAZARDOUS SITUATION WHICH, IF NOT AVOIDED, MAY RESULT IN MINOR OR MODERATE INJURY.

**NOTE**

An operating procedure, practice condition, etc. which is essential to emphasize.

**SERVICE HINT**

A helpful suggestion that will make the service being performed a little easier and/or faster.

Also note that particular service operations may require the use of special tools designed for specific purposes. These special tools can be found in the Special Tools Section of this publication.

## SAFETY PRECAUTIONS

 **WARNING**

### FASTENERS

DISCARD USED FASTENERS. ALWAYS USE NEW FASTENERS TO COMPLETE A REPAIR. FAILURE TO DO SO COULD RESULT IN FAILURE OF THE PART OR MATING PARTS, LOSS OF VEHICLE CONTROL, PERSONAL INJURY, OR PROPERTY DAMAGE.

LOOSE OR OVER TORQUED FASTENERS CAN CAUSE COMPONENT DAMAGE, LOSS OF VEHICLE CONTROL, PROPERTY DAMAGE, OR SEVERE PERSONAL INJURY. MAINTAIN CORRECT TORQUE VALUE AT ALL TIMES. CHECK TORQUE VALUES ON A REGULAR BASIS AS SPECIFIED, USING A TORQUE WRENCH THAT IS REGULARLY CALIBRATED. TORQUE VALUES SPECIFIED IN THIS TECHNICAL PUBLICATION ARE FOR HENDRICKSON SUPPLIED FASTENERS ONLY. IF NON HENDRICKSON FASTENERS ARE USED, FOLLOW TORQUE SPECIFICATION LISTED IN THE VEHICLE MANUFACTURER'S SERVICE MANUAL.

 **WARNING**

### LOAD CAPACITY

ADHERE TO THE PUBLISHED CAPACITY RATINGS FOR THE SUSPENSION. ADD ON AXLE ATTACHMENTS AND OTHER LOAD TRANSFERRING DEVICES CAN INCREASE THE SUSPENSION LOAD ABOVE ITS RATED AND APPROVED CAPACITIES, WHICH CAN RESULT IN COMPONENT DAMAGE AND LOSS OF VEHICLE CONTROL, POSSIBLY CAUSING PERSONAL INJURY OR PROPERTY DAMAGE.

 **WARNING**

### MODIFYING COMPONENTS

DO NOT MODIFY OR REWORK PARTS WITHOUT AUTHORIZATION FROM HENDRICKSON. DO NOT SUBSTITUTE PARTS OF THE SUSPENSION. USE OF MODIFIED OR REPLACEMENT PARTS NOT AUTHORIZED BY HENDRICKSON MAY NOT MEET HENDRICKSON'S SPECIFICATIONS, AND CAN RESULT IN COMPONENT DAMAGE, LOSS OF VEHICLE CONTROL, AND POSSIBLE PERSONAL INJURY OR PROPERTY DAMAGE. USE ONLY HENDRICKSON AUTHORIZED REPLACEMENT PARTS.

 **WARNING**

### TORCH/WELDING

DO NOT USE A CUTTING TORCH TO REMOVE ANY ATTACHING FASTENERS. THE USE OF HEAT ON SUSPENSION COMPONENTS WILL ADVERSELY AFFECT THE STRENGTH OF THESE PARTS. EXERCISE EXTREME CARE WHEN HANDLING OR PERFORMING MAINTENANCE IN THE AREA OF THE MAIN SUPPORT MEMBER. DO NOT CONNECT ARC WELDING GROUND LINE TO THE MAIN SUPPORT MEMBER. DO NOT STRIKE AN ARC WITH THE ELECTRODE ON THE MAIN SUPPORT MEMBER ASSEMBLY AND AXLE. DO NOT USE HEAT NEAR THE MAIN SUPPORT MEMBER ASSEMBLY. DO NOT NICK OR GOUGE THE MAIN SUPPORT MEMBER ASSEMBLY. SUCH IMPROPER ACTIONS CAN CAUSE DAMAGE TO THE MAIN SUPPORT MEMBER ASSEMBLY COULD FAIL, AND CAUSE LOSS OF VEHICLE CONTROL AND POSSIBLE PERSONAL INJURY OR PROPERTY DAMAGE.

 **CAUTION**

### PROCEDURES AND TOOLS

A TECHNICIAN USING A SERVICE PROCEDURE OR TOOL WHICH HAS NOT BEEN RECOMMENDED BY HENDRICKSON MUST FIRST SATISFY HIMSELF THAT NEITHER HIS SAFETY NOR THE VEHICLE'S SAFETY WILL BE JEOPARDIZED BY THE METHOD OR TOOL SELECTED. INDIVIDUALS DEVIATING IN ANY MANNER FROM THE INSTRUCTIONS PROVIDED WILL ASSUME ALL RISKS OF CONSEQUENTIAL PERSONAL INJURY OR DAMAGE TO EQUIPMENT INVOLVED.

 **WARNING**

DO NOT AT ANY TIME WORK AROUND OR UNDER A VEHICLE SUPPORTED ONLY ON LIFTING DEVICES. THE VEHICLE MUST BE SECURELY CHOCKED AND SUPPORTED ON RIGID STANDS OF SUFFICIENT STRENGTH BEFORE WORK MAY COMMENCE.

 **WARNING****AIR SPRING INFLATION AND DEFLATION**

AIR SPRING ASSEMBLIES MUST BE DEFLATED PRIOR TO LOOSENING ANY CLAMP GROUP HARDWARE. UNRESTRICTED AIR SPRING ASSEMBLIES CAN VIOLENTLY SHIFT. DO NOT INFLATE AIR SPRING ASSEMBLIES WHEN THEY ARE UNRESTRICTED. AIR SPRING ASSEMBLIES MUST BE RESTRICTED BY SUSPENSION OR OTHER ADEQUATE STRUCTURE. DO NOT INFLATE BEYOND PRESSURES RECOMMENDED BY AIR SPRING MANUFACTURER, CONTACT HENDRICKSON TECHNICAL SERVICES FOR DETAILS. IMPROPER USE OR OVER INFLATION WILL CAUSE AIR SPRING ASSEMBLIES TO BURST, CAUSING PROPERTY DAMAGE AND/OR SEVERE PERSONAL INJURY.

 **WARNING**

PRIOR TO AND DURING DEFLATION AND INFLATION OF THE AIR SUSPENSION SYSTEM, ENSURE THAT ALL PERSONNEL AND EQUIPMENT ARE CLEAR FROM UNDER THE VEHICLE AND AROUND THE SERVICE AREA, FAILURE TO DO SO CAN CAUSE SERIOUS PERSONAL INJURY, DEATH, OR PROPERTY DAMAGE.

 **CAUTION****AIR SPRING INFLATION**

INFLATE THE SUSPENSION SLOWLY, ENSURE THAT THE RUBBER BLADDER OF THE AIR SPRING INFLATES UNIFORMLY AND IS NOT BINDING. FAILURE TO DO SO CAN CAUSE DAMAGE TO THE AIR SPRING AND/OR AIR SPRING MOUNTING BRACKETS VOIDING WARRANTY.

 **CAUTION****AIR SPRING DEFLATION**

IF THE AIR SPRING IS BEING REMOVED, IT IS MANDATORY TO LUBRICATE THE LOWER AIR SPRING FASTENERS WITH PENETRATING OIL AND REMOVE WITH HAND TOOLS TO PREVENT DAMAGE TO THE LOWER AIR SPRING MOUNTING STUD. FAILURE TO DO SO CAN CAUSE COMPONENT DAMAGE AND VOID WARRANTY.

 **WARNING****PERSONAL PROTECTIVE EQUIPMENT**

ALWAYS WEAR PROPER EYE PROTECTION AND OTHER REQUIRED PERSONAL PROTECTIVE EQUIPMENT TO HELP PREVENT PERSONAL INJURY WHEN PERFORMING VEHICLE MAINTENANCE, REPAIR OR SERVICE.

 **WARNING****PARTS CLEANING**

SOLVENT CLEANERS CAN BE FLAMMABLE, POISONOUS, AND CAUSE BURNS. TO HELP AVOID SERIOUS PERSONAL INJURY, CAREFULLY FOLLOW THE MANUFACTURER'S PRODUCT INSTRUCTIONS AND GUIDELINES AND THE FOLLOWING PROCEDURES:

1. WEAR PROPER EYE PROTECTION.
2. WEAR CLOTHING THAT PROTECTS YOUR SKIN.
3. WORK IN A WELL-VENTILATED AREA.
4. DO NOT USE GASOLINE, OR SOLVENTS THAT CONTAIN GASOLINE. GASOLINE CAN EXPLODE.
5. HOT SOLUTION TANKS OR ALKALINE SOLUTIONS MUST BE USED CORRECTLY. FOLLOW THE MANUFACTURER'S RECOMMENDED INSTRUCTIONS AND GUIDELINES CAREFULLY TO HELP PREVENT PERSONAL ACCIDENT OR INJURY.

DO NOT USE HOT SOLUTION TANKS OR WATER AND ALKALINE SOLUTIONS TO CLEAN GROUND OR POLISHED PARTS. DOING SO WILL CAUSE DAMAGE TO THE PARTS AND VOID WARRANTY.

**WARNING****QUIK-ALIGN FASTENERS**

DO NOT ASSEMBLE QUIK-ALIGN JOINT WITHOUT PROPER FASTENERS. USE ONLY DACROMET PLUS XL PLATED FASTENERS TO SUSTAIN PROPER CLAMP FORCE. FAILURE TO DO SO CAN CAUSE LOSS OF VEHICLE CONTROL, PROPERTY DAMAGE OR PERSONAL INJURY.

ENSURE THAT QUIK-ALIGN FASTENERS TORQUE VALUE IS SUSTAINED AS RECOMMENDED IN THE TORQUE SPECIFICATIONS SECTION OF THIS PUBLICATION. FAILURE TO DO SO CAN CAUSE LOSS OF VEHICLE CONTROL RESULTING IN PERSONAL INJURY OR PROPERTY DAMAGE.

**WARNING****U-BOLT CLAMP GROUP CONNECTION**

IT IS IMPORTANT THAT THE U-BOLT CLAMP GROUP CONNECTION BE PROPERLY ALIGNED AND HAVE THE PROPER TIGHTENING TORQUE VALUES MAINTAINED. METAL SURFACES CAN WORK AND WEAR AGAINST OTHER RELATED CLAMP GROUP COMPONENTS IF NOT PROPERLY ALIGNED OR PROPERLY TIGHTENED TO MAINTAIN THE PROPER CLAMP FORCE. FAILURE TO DO SO CAN CAUSE PREMATURE COMPONENT WEAR, POSSIBLE SEPARATION OF THE CLAMP GROUP, CAUSING LOSS OF VEHICLE CONTROL, PROPERTY DAMAGE, OR PERSONAL INJURY.

**WARNING****SHOCK ABSORBERS**

THE SHOCK ABSORBERS ARE THE REBOUND TRAVEL STOPS FOR THE SUSPENSION. ANYTIME THE AXLE ON A COMFORT AIR SUSPENSION IS SUSPENDED IT IS MANDATORY THAT THE SHOCK ABSORBERS REMAIN CONNECTED. FAILURE TO DO SO CAN CAUSE THE AIR SPRINGS TO SEPARATE FROM THE PISTON AND RESULT IN PREMATURE AIR SPRING FAILURE.

# SECTION 4 Parts List

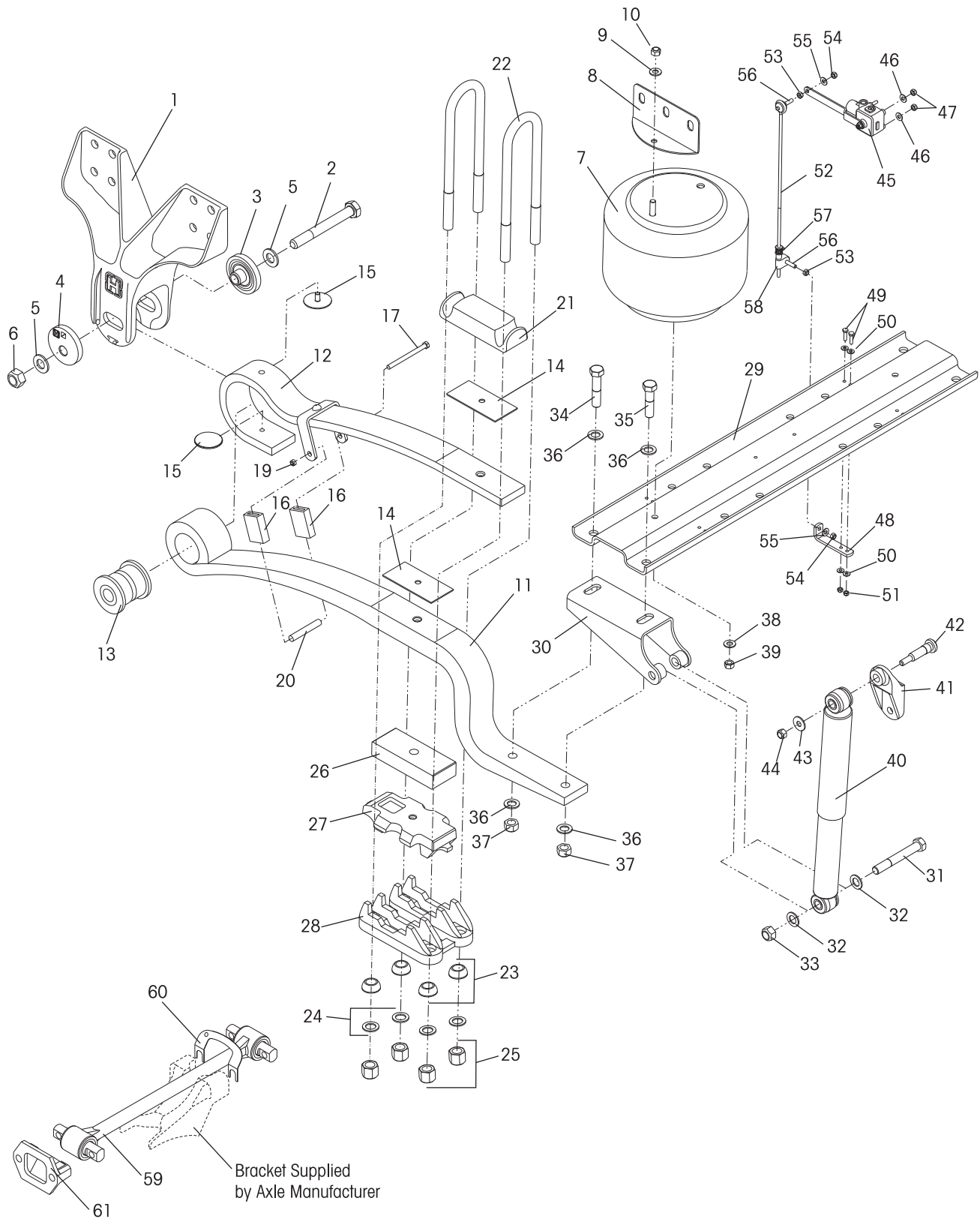





KEY NO.	PART NO.	DESCRIPTION	NO.REQ.	KEY NO.	PART NO.	DESCRIPTION	NO.REQ.
1	60784-000	Frame Hanger	2	29		Cross Channel (Contact Hendrickson Tech Services for proper Cross Channel)	1
	60632-001	<b>QUIK-ALIGN® Service Kit, Axle Set</b> (Includes Key Nos. 2-6)			57356-000	Lower Shock Bracket Assembly (Includes Key Nos. 30-33)	2
	34013-103	<b>Pivot Bushing Service Kit, One Side</b> (Includes Key Nos. 2, 5-6, 13, 15)		30		*Lower Shock Bracket	2
2	64107-000	1"-8 UNC Bolt 7.50"	2	31	50764-002	¾"-10 UNC Bolt - 5.50"	2
3	64633-000	QUIK-ALIGN Concentric Collar	3	32	22962-001	¾" Hardened Washer	4
4	64632-000	QUIK-ALIGN Eccentric Collar	1	33	49842-000	¾"-10 UNC Locknut	2
5	22962-035	1" Hardened Washer	4		50763-004	<b>Cross Channel Fastener Service Kit, Axle Set</b> (Includes Key Nos. 34-37)	
6	64108-000	1"-8 UNC Locknut	2	34	50764-003	¾"-10 UNC Bolt - 3.50"	2
	60925-002	Air Spring Assembly (Includes Key Nos. 7-10)	2	35	50764-005	¾"-10 UNC Bolt - 3.00"	2
	60929-002	Air Spring Assembly Front Engine (Includes Key Nos. 7-10)	2	36	22962-001	¾" Hardened Washer	8
7		*Air Spring	2	37	49842-000	¾"-10 UNC Locknut	4
8	57096-002	Air Spring Bracket	2		49177-006	<b>Air Spring Fastener Service Kit, Axle Set</b> (Includes Key Nos. 38-39)	
9	22962-014	½" Flat Washer	2	38	22962-014	½" Hardened Washer	2
10	17700-010	½"-13UNC Nylocknut	2	39	17700-010	½"-13 UNC Nylocknut	2
	60779-000	Main Support Assembly (Includes Key Nos. 11-20)	2	40	60998-001	Shock Absorber	2
11		*Main Support Member	2		57322-002	Upper Shock Bracket Assembly (Includes Key Nos. 41-44)	2
12		*Secondary Leaf	2	41		*Upper Shock Bracket	2
13	58648-000	Pivot Bushing	2	42	50368-000	½"-13 UNC Serrated Shank Bolt	2
14	37674-051	Liner	4	43	22962-031	½" Hardened Washer	2
15	64817-000	Puck	4	44	49846-000	½"-13 UNC Locknut	2
	49175-026	<b>Spring Clip Fastener Service Kit, Axle Set</b> (Includes Key Nos.16-19)			59013-000	<b>Height Control Valve Service Kit, Axle Set</b> (Includes Key Nos. 45-47)	
16	64272-000	Spring Clip Sleeve	4	45		*Height Control Valve	1
17	37042-002	⅞"-14 UNC Bolt	2	46		*¼" Hardened Washer	2
18	22962-027	⅞" Washer (Not Shown)		47		*¼"-20 UNC Locknut	2
19	17700-007	⅞"-14 UNC Nut	2			<b>HCV Linkage Lower Bracket Service Kit</b> (Includes Key Nos. 48-51)	
20		*Clip Bolt Spacer	2		57430-000	All Except Rear Engine	
21	56805-000	Top Pad (All except 15,000 lb. capacity)	2		57430-003	Rear Engine Only	
	57724-000	Top Pad (15,000 lb. capacity)	2	48	56789-000	HCV Linkage Bracket	1
		<b>U-bolt Service Kit, Axle Set</b> ¾" Specify Length,(Includes Key Nos. 22-25)			58367-000	HCV Linkage Bracket (Rear Engine)	
	48718-	¾"-15,000 lb. capacity, (Includes Key Nos. 22, 24-25)		49	56935-002	¼"-20 UNC Bolt - 1.00"	2
	48718-104	¾"-15,000 lb. capacity, (Includes Key Nos. 22, 24-25)		50	22962-028	¼" Hardened Washer	4
22	47417-	¾"-14 UNF U-bolt - Specify Length	4	51	49983-000	¼"-20 UNC Locknut	2
	49684-014	¾" 26 UNF U-bolt - 12.5" (15,000 lbs.Capacity)	4		58994-	Height Control Valve Linkage Assembly, Specify Length (Includes Key Nos. 52-58)	1
23	48574-000	Spherical Washer	8	52		*HCV Linkage Rod	1
24	22962-002	⅞" Hardened Flat Washer	8	53		*⅞"-18 UNC Jam Nut	2
	22962-001	¾" Hardened Flat Washer (15,000 lb. Capacity)	8	54		*⅞"-18 UNC Locknut	2
25	50765-000	⅞" 14UNF U-Bolt Locknut	8	55		*⅞" Hardened Washer	2
	49685-000	¾" 16UNF U-Bolt Locknut (15,000 lb. Capacity)	8	56		*⅞"-18 UNC Stud	2
26	48531-014	Spacer 1.5" (As Required)	2	57		*Valve Arm Clamp	1
27		Spring Seat	2	58		*Adjustable Valve Arm Joint	1
		Meritor RS15-120		59	62000-	Transverse Torque Rod Assembly, Specify Length	1
	57022-010	4.5° Pinion Angle LH/RH Meritor RS21-145, RS23-160		60	49689-000	Torque Rod Shim	As Req.
	56501-006	4.5° Pinion Angle LH/RH		61	22186-000	Transverse Torque Rod Frame Bracket	1
	56501-019	0.0° Pinion Angle LH/RH					
	56501-020	4.5° Pinion Angle LH/RH					
	56501-021	0.0° Pinion Angle LH/RH Meritor RC23-160					
	56501-020	Negative 4.5° Pinion Angle LH/RH					
28		Axle Bottom Cap	2				
		Meritor RS15-120					
	57024-000	2-5.0° Pinion Angle LH/RH Meritor RS21-145, RS23-160					
	50216-000	0-9.5° Pinion Angle LH/RH Meritor RC23-160					
	50216-000	Negative 0-9.5° Angle LH/RH					

**NOTE**

\* Item included in assembly only, part not sold separately.

## SECTION 5

# Special Tools

These shop made tools are designed to install and remove pivot bushing and torque rod bushing. Bushing tools are made from cold rolled steel or equivalent. Drawing is for reference only, Hendrickson does not supply this tools.

### PIVOT BUSHING TOOLS

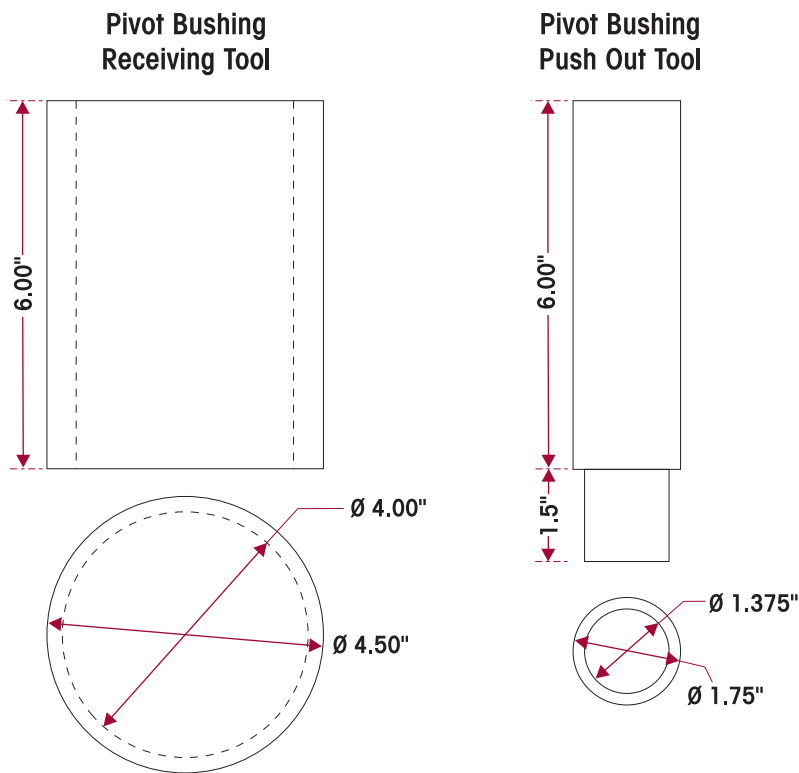

### TRANSVERSE TORQUE ROD BUSHING TOOLS

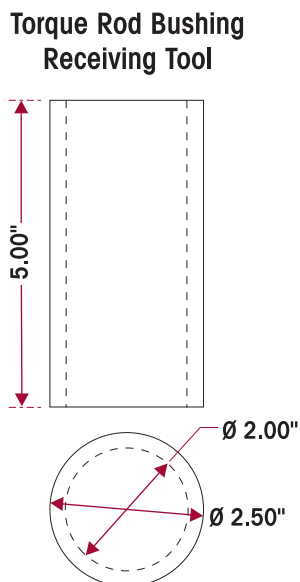

## SECTION 6

## Preventive Maintenance

Following appropriate inspection procedures is important to help ensure the proper maintenance and operation of the COMFORT AIR suspension system and component parts function to their highest efficiency. Look for bent or cracked parts. Replace all worn or damaged parts.

**HENDRICKSON RECOMMENDED PREVENTIVE MAINTENANCE INTERVALS**

- Preparation for delivery
- The first 1,000 miles
- **On-highway** – every 20,000 miles or every 6 months, whichever comes first

**COMPONENT INSPECTION**

- **Air spring** — Visually inspect the outer surface of the air spring for chafing, uneven wear, cracks or any signs of component damage.
- **Clamp group** — Visually inspect for any loose or damaged fasteners. Verify the U-bolt locknuts have the proper torque values maintained. See the U-bolt Locknuts in this section.
- **Fasteners** — Look for any loose or damaged fasteners on the entire suspension. Make sure all fasteners are tightened to a torque value within the specified torque range. See Torque Specification Section of this publication for Hendrickson recommended torque requirements. Use a calibrated torque wrench to check torque in the tightening direction. As soon as the fastener starts to move, record the torque. Correct the torque if necessary.

**NOTE**

Hendrickson recommends the use of Grade 8 bolts and Grade C locknuts for all suspension component attachments.

- **Frame hanger** — Inspect for any signs of loosening or damage. Check for cracks. Replace if necessary, see the Component Replacement Section of this publication.
- **Height control valve and air lines** — Check the suspension air system for air leaks. Check all air lines for proper routing. Check for chafing or pinched air lines. Check the height control valve linkage for damage or interference with peripheral components.
- **Transverse torque rods** — All torque rods must be inspected for looseness, torn or shredded rubber, bushing walk-out, and for proper fastener torque. If there is metal-to-metal contact in the bushing joint, this is a sign of excessive bushing wear and the bushing needs to be replaced. See Transverse Torque Rods in this section.
- **Shock absorbers** — Look for any signs of dents or leakage. Misting is not considered a leak. See Shock Absorber Inspection in this section.
- **Tire wear** — Inspect the tires for wear patterns that may indicate suspension damage or misalignment. Verify proper alignment and correct as necessary.
- **Top pad** — Look for cracks or damage. Replace if necessary, see the Component Replacement Section of this publication.
- **Wear and damage** — Inspect all parts of the suspension for wear and damage. Look for bent or cracked parts.

See vehicle manufacturer's applicable publications for other preventive maintenance requirements.

## MAIN SUPPORT MEMBER ASSEMBLY BUSHINGS

Bushings should function satisfactorily during normal vehicle operation. However premature bushing wear can occur and will require replacement. The main support member assembly pivot bushing should be replaced if it exhibits excessive fore-aft movement or the vehicle is experiencing excessive tire wear on the rear axle. For instructions on bushing replacement, see the Component Replacement Section of this publication.

## U-BOLT LOCKNUTS

1. U-bolt locknuts must be re-torqued at 1,000 miles or first service interval.
2. Thereafter, follow 6 months/20,000 mile inspection and re-torque interval.

### NOTE

Hendrickson Truck Suspension Systems U-bolt clamp group hardware for the COMFORT AIR suspension are phosphate and oil coated  $\frac{3}{4}$ "-16 UNF Grade C high locknuts and  $\frac{3}{4}$ "-16 UNF Grade 8 U-bolts.



### WARNING

IT IS IMPORTANT THAT THE U-BOLT CLAMP GROUP CONNECTION BE PROPERLY ALIGNED AND HAVE THE PROPER TIGHTENING TORQUE VALUES MAINTAINED. METAL SURFACES CAN WORK AND WEAR AGAINST OTHER RELATED CLAMP GROUP COMPONENTS IF NOT PROPERLY ALIGNED OR PROPERLY TIGHTENED TO MAINTAIN THE PROPER CLAMP FORCE. FAILURE TO DO SO CAN CAUSE PREMATURE COMPONENT WEAR, POSSIBLE SEPARATION OF THE CLAMP GROUP, CAUSING LOSS OF VEHICLE CONTROL, PROPERTY DAMAGE, OR PERSONAL INJURY.

FIGURE 6-1

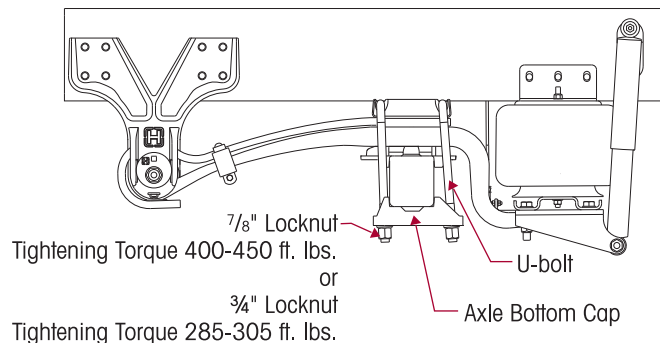
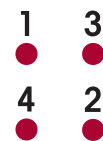

FIGURE 6-2

Tighten the U-bolt locknuts evenly in 50 foot pounds increments in the proper pattern to achieve uniform bolt tension, see Figure 6-2. **DO NOT EXCEED SPECIFIED TORQUE ON U-BOLT LOCKNUTS.**

- 19,000 to 23,000 pound capacity equipped with  $\frac{7}{8}$ " locknuts tighten to 400-450 foot pounds torque.
- 15,000 pound capacity equipped with  $\frac{3}{4}$ " locknuts tighten to 285-305 foot pounds torque.



## SHOCK ABSORBER INSPECTION

Hendrickson uses a long service life, premium shock absorber on all COMFORT AIR suspensions. If shock absorber replacement is necessary, Hendrickson recommends that the shock absorbers be replaced with identical Hendrickson Genuine parts for servicing. Failure to do so will affect the suspension performance, durability, and will void the warranty.

Inspection of the shock absorber can be performed by doing a heat test, and a visual inspection. For instructions on shock absorber replacement see the Component Replacement Section of this publication. It is not necessary to replace shock absorbers in pairs if one shock absorber requires replacement.

### HEAT TEST

1. Drive the vehicle at moderate speeds on rough road for a minimum of fifteen minutes.

**WARNING**

DO NOT GRAB THE SHOCK AS IT COULD POSSIBLY CAUSE PERSONAL INJURY.

2. Lightly touch the shock body carefully below the dust cover.
3. Touch the frame to get an ambient reference. A warm shock absorber is acceptable, a cold shock absorber should be replaced.
4. To inspect for an internal failure, remove and shake the suspected shock. Listen for the sound of metal parts rattling inside. Rattling of metal parts can indicate that the shock has an internal failure.

**FIGURE 6-3**



### VISUAL INSPECTION

Look for these potential problems when doing a visual inspection. Inspect the shock absorbers fully extended. Replace as necessary.

**FIGURE 6-4**



### LEAKING VS. MISTING SHOCK VISUAL INSPECTION

The inspection must not be conducted after driving in wet weather or a vehicle wash. Shocks needs to be free from water. Many shocks are often mis-diagnosed as failures. Misting is the process whereby very small amounts of shock fluid evaporate at a high operating temperature through the upper seal of the shock. When the "mist" reaches the cooler outside air, it condenses and forms a film on the outside of the shock body. Misting is perfectly normal and necessary function of the shock. The fluid which evaporates through the seal area helps to lubricate and prolong the life of the seal.

A shock that is truly leaking and needs to be replaced will show signs of fluid leaking in streams from the upper seal. These streams can easily be seen when the shock is fully extended, underneath the main body (dust cover) of the shock. Look for these potential problems when doing a visual inspection. Inspect the shock absorbers fully extended. Replace as necessary.

#### NOTE

The COMFORT AIR suspension is equipped with a premium seal on the shock, however this seal will allow for misting to appear on the shock body (misting is not a leak and is considered acceptable).

FIGURE 6-5

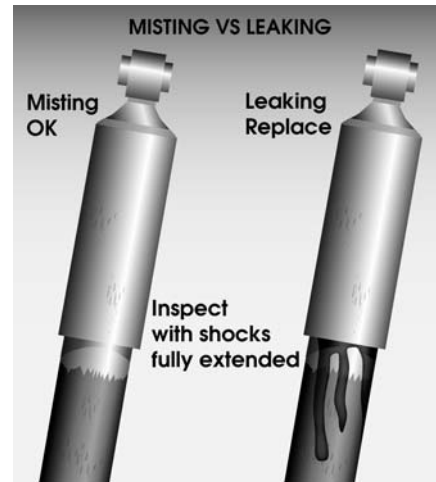

If the shock is damaged install new shock absorber and replace as detailed in the Component Replacement Section of this publication.

### TRANSVERSE TORQUE RODS

The length of the transverse torque rod is determined by the vehicle manufacturer in order to center the axles under the frame. The transverse torque rod maintains lateral axle position during cornering. See Figure 6-6. The mounting bracket at the axle end of the torque rod is furnished and welded into position on the axle housing by the axle or vehicle manufacturer.

FIGURE 6-6

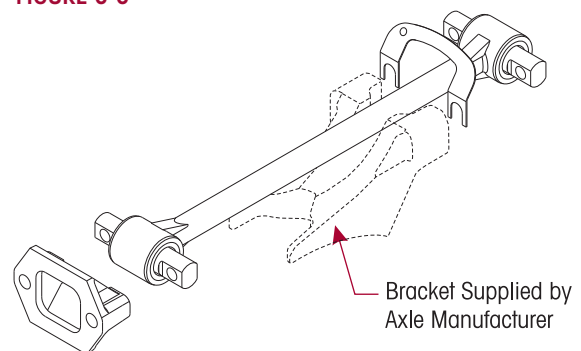

Torque rod end attaching fasteners are furnished by the vehicle manufacturer. It is important that the torque of the nuts be checked during preventive maintenance service. Follow the vehicle manufacturer's specifications for torque values.

All torque rods should be inspected for looseness and torn or shredded rubber. With brakes applied, slowly rock an empty vehicle with power while a mechanic visually checks the action at both ends. Or with the vehicle shut down, a lever check can be made with a long pry bar placed under each rod end and pressure applied.

Torque Rod ends can be renewed by pressing out the worn end, and installing a replacement bushing. A two-piece torque rod is also available to cut and weld to the desired length, see Hendrickson publication no. 59310-001.

#### NOTE

Hendrickson recommends the use of Grade 8 bolts and Grade C locknuts for all torque rod attachments.

## SECTION 7

# Alignment & Adjustments

### RIDE HEIGHT SETTING

Proper ride height is essential for maximum ride quality and performance. Proper adjustment of the height control valve is described below. If the valve or linkage assembly becomes damaged they will require replacement. See the Component Replacement Section of this publication.

1. Place vehicle on level floor.
2. Free and center all suspension joints by slowly moving the vehicle back and forth without applying the brakes. When coming to a complete stop, make sure the parking brakes are released.
3. Chock front wheels of vehicle.
4. Loosen the clamp on the adjustable extension rod.
5. Remove the fasteners at height control valve leveling arm.
6. Verify that air system is at full operating pressure. Exhaust the air in the air springs to relax the suspension. Then refill the air springs to proper ride height.

#### Dimension A

The ride height is measured at the bottom of the frame rail to the bottom of the main support member assembly as shown in Figure 7-1. The ride height is  $4 \frac{7}{8}'' \pm \frac{1}{4}''$  as shown in the matrix, **Dimension A**.

#### Dimension B

This option to measure the normal running length of the shock absorber will measure the ride height on the shock from center of eye to center of eye, see **Dimension B** in Figure 7-1. The specific running length of the shock absorber varies per specific OEM applications as shown in the matrix.

**FIGURE 7-1**

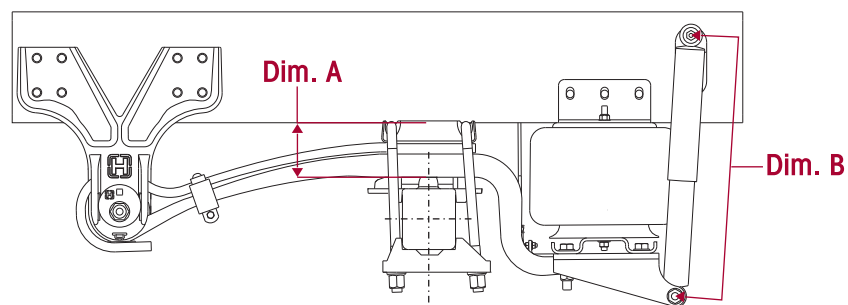

OEM AND MODEL	DIMENSION A	DIMENSION B
	RIDE HEIGHT At the Bottom of the Frame Rail to the Bottom of the Main Support Member	SHOCK ABSORBER LENGTH At Ride Height With a Tolerance Of $\frac{1}{4}''$
BLUE BIRD - RE/QBRE	4 $\frac{7}{8}''$	22.75"
BLUE BIRD - TCFE/CSFE	4 $\frac{7}{8}''$	22.75"
BLUE BIRD - TSFE/CIFE	4 $\frac{7}{8}''$	23"
BLUE BIRD - TCFE FLAT FLOOR	4 $\frac{7}{8}''$	22.75"
BLUE BIRD - A3FE/A3RE/BBCV	4 $\frac{7}{8}''$	22.68"
BLUE BIRD - C4RE	4 $\frac{7}{8}''$	22.75"



7. Use a 1/8" wooden dowel rod (golf tee) to set the neutral position for the height control valve by aligning hole in leveling arm with hole in control valve cover, as shown in Figure 7-2. **DO NOT** use a metal rod or nail as this may cause damage to the height control valve.
8. Reposition the extension rod in the rubber joint.
9. Attach washer and locknut and tighten to  80-90 inch pounds torque.
10. Tighten clamp on the rubber joint with a screwdriver until securely fastened.

FIGURE 7-2

**NOTE**

During cycle operation of the height control valve it is normal to experience a limited amount of exhaust noise.

11. Remove wheel chocks.

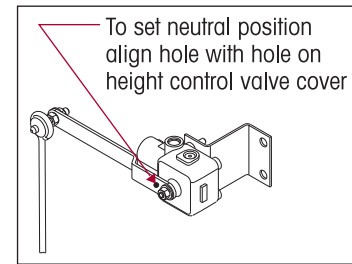
**ALIGNMENT**

Proper alignment is essential for maximum ride quality, performance, and tire service life. The recommended alignment procedure is described below. This procedure should be performed if excessive or irregular tire wear is observed, or any time the Main Support Member Assembly is removed for service.

The following procedure should be performed after all repairs are completed.

**NOTE**

It is important to have the QUIK-ALIGN locknut pre-torqued to  100 foot pounds on the left side of vehicle only. All other suspension fasteners tightened to their specified torque values. The total range of adjustment is 1.0".

**NOTE**

Use a new QUIK-ALIGN kit Part No. 60632-001 for any axle alignment or disassembly of the QUIK-ALIGN connection. This ensures proper torque is applied to the connection.

1. Place vehicle on level floor.
2. Free and center all suspension joints by slowly moving the vehicle back and forth without applying the brakes. When coming to a complete stop make sure the parking brakes are released.
3. Chock front wheels of vehicle.
4. Verify proper ride height is set. For proper ride height setting see Ride Height Setting in this section.
5. Using "C" clamps, securely clamp a six foot piece of STRAIGHT bar stock or angle iron across the lower frame flange as shown in Figure 7-3. Select a location as far forward of the drive axle as possible where components will not interfere.
6. Accurately square straight edge to frame using a carpenter's square.

FIGURE 7-3

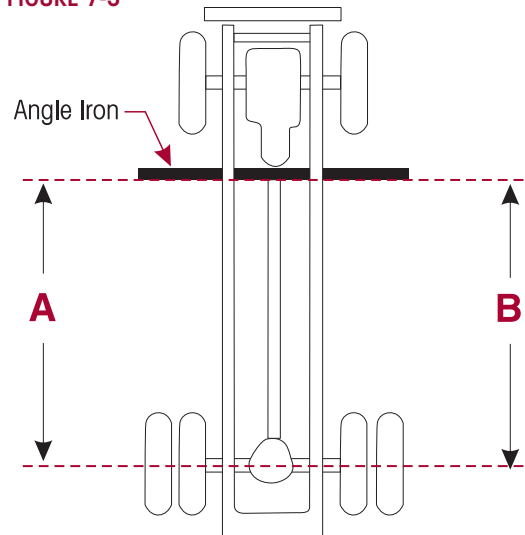

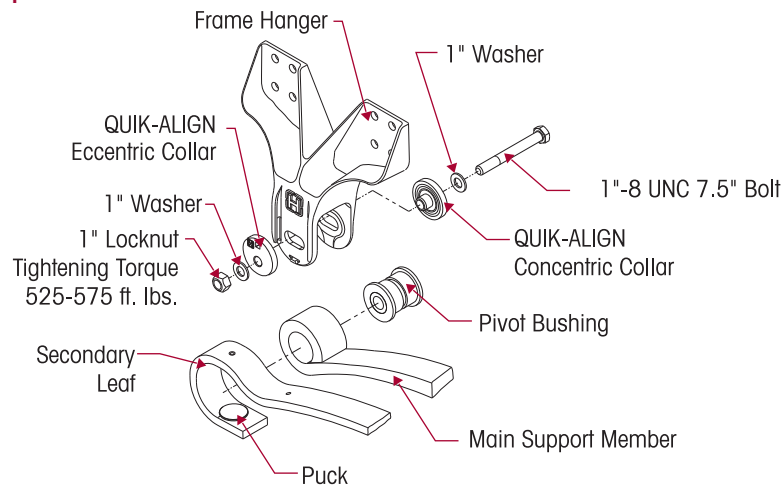

7. Using a measuring tape, measure from straight edge to forward face of drive axle arm at the centerline of the spring seat on both sides of vehicle as shown in Figure 7-3. If both sides measure within  $\frac{1}{8}$ " of being equal, alignment of drive axle is acceptable. If **A** and **B** differ by more than  $\frac{1}{8}$ " the following procedure must be followed.
  - Loosen the left pivot bolt locknut to snug (100 foot pounds), see Figure 7-4. This will hold the eccentric flanged washer in place against the hanger face, and within the adjustment guide, but loose enough to permit the eccentric flanged washer to rotate freely.
  - Using an alignment tool or  $\frac{1}{2}$ " square drive breaker bar rotate the left eccentric alignment collar to align axle (Clockwise rotation moves axle forward, counter clockwise rotation moves axle rearward). A 90° rotation of the QUIK-ALIGN collar will move axle fore and aft  $\pm \frac{1}{2}$ " from center.

**FIGURE 7-4**

**WARNING**

DO NOT ASSEMBLE QUIK-ALIGN JOINT WITHOUT PROPER FASTENERS. USE ONLY DACROMET PLUS XL PLATED FASTENERS TO SUSTAIN PROPER CLAMP FORCE. FAILURE TO DO SO CAN CAUSE LOSS OF VEHICLE CONTROL, PROPERTY DAMAGE OR PERSONAL INJURY.

ENSURE THAT QUIK-ALIGN FASTENERS TORQUE VALUE IS SUSTAINED AS RECOMMENDED IN THE TORQUE SPECIFICATION SECTION OF THIS PUBLICATION. FAILURE TO SO CAN CAUSE LOSS OF VEHICLE CONTROL RESULTING IN PERSONAL INJURY OR PROPERTY DAMAGE.

- Measure from straight edge to forward face of axle arm to verify both sides of axle are equal and tighten the 1" QUIK-ALIGN locknuts to 525-575 foot pounds torque.

**NOTE** The Eccentric collar is located on the outside frame on the left side of chassis with the concentric collar on the inside. On the right side of chassis are (2) concentric collars located on the inside and outside of the frame hanger.

**NOTE** Axle adjustment is applied to LEFT side of vehicle only. If adjustment to the right side of vehicle is necessary, it will require replacement of the outside concentric collar with an eccentric collar (Hendrickson Part No. 64096-000) and repeat step 7 on the right side of vehicle.

8. Following alignment of axle, move vehicle back and forth several times prior to removing straight edge from frame, and recheck measurements to confirm adjustments.
9. Repeat steps 7 and 8 until alignment is achieved.
10. Remove wheel chocks.

## SECTION 8

## Component Replacement

**FRAME HANGER**

The frame hanger should function satisfactorily during normal vehicle operation. Replacement is required when the frame hanger is damaged or worn.

**DISASSEMBLY**

1. Chock wheels of axle.
2. Raise frame of vehicle to remove load from suspension.

**WARNING**

VEHICLE MUST BE FIRMLY SUPPORTED WITH JACK STANDS PRIOR TO SERVICING. FAILURE TO DO SO CAN RESULT IN PERSONAL INJURY OR PROPERTY DAMAGE.

**WARNING**

PRIOR TO AND DURING DEFLATION AND INFLATION OF THE AIR SUSPENSION SYSTEM, ENSURE THAT ALL PERSONNEL AND EQUIPMENT ARE CLEAR FROM UNDER THE VEHICLE AND AROUND THE SERVICE AREA, FAILURE TO DO SO CAN CAUSE SERIOUS PERSONAL INJURY, DEATH, OR PROPERTY DAMAGE.

3. See additional Air Spring Cautions and Warnings in the Important Safety Notice Section of this publication prior to deflating or inflating the air system.
4. Verify air is removed from the system.
5. Remove the dacromet locknut and washers, 1" pivot bolt, and QUIK-ALIGN® collars that connect main support member assembly to frame hanger, see Figure 8-1.
6. Remove the fasteners that attach the frame hanger to the vehicle per vehicle manufacturer specifications.
7. Remove frame hanger.

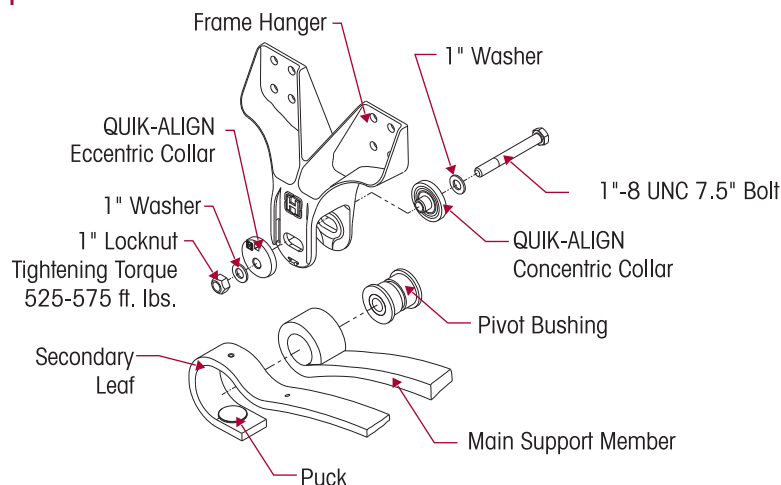
**FIGURE 8-1****ASSEMBLY**

1. Install new frame hanger by attaching fasteners per vehicle manufacturer specifications.
2. Install the new QUIK-ALIGN collars, new 1" dacromet pivot bolt, washers, and locknut that attach the main support member assembly to the frame hanger. Verify that the nose of each QUIK-ALIGN collar is installed into the pivot-bushing sleeve, and the flanged side is flat against the hanger face within the alignment guides.

**NOTE**

The eccentric collar is located on the outside frame on the left side of chassis with the concentric collar on the inside. On the right side of chassis are (2) concentric collars located on the inside and outside of the frame hanger.

3. Snug the left pivot bolt to 100 foot pounds torque. Tighten the right pivot bolt to 525-575 foot pounds torque.
4. Remove jack stands and lower frame of vehicle.
5. Air up the system.
6. Align the rear axle (see alignment in the Alignment & Adjustments Section of this publication).
7. Remove wheel chocks.

### MAIN SUPPORT MEMBER ASSEMBLY

The Main Support Member Assembly should function satisfactorily during normal vehicle operation. Replacement is only required when the Main Support Member Assembly is damaged or worn.

#### DISASSEMBLY

1. Chock wheels of axle.
2. Raise frame of vehicle to remove load from suspension.

**WARNING**

VEHICLE MUST BE FIRMLY SUPPORTED WITH JACK STANDS PRIOR TO SERVICING. FAILURE TO DO SO CAN RESULT IN PERSONAL INJURY OR PROPERTY DAMAGE.



**WARNING**

PRIOR TO AND DURING DEFLATION AND INFLATION OF THE AIR SUSPENSION SYSTEM, ENSURE THAT ALL PERSONNEL AND EQUIPMENT ARE CLEAR FROM UNDER THE VEHICLE AND AROUND THE SERVICE AREA, FAILURE TO DO SO CAN CAUSE SERIOUS PERSONAL INJURY, DEATH, OR PROPERTY DAMAGE.

3. See additional Air Spring Cautions and Warnings in the Important Safety Notice Section of this publication prior to deflating or inflating the air system.
4. Verify air is removed from the system, and remove height control valve extension rod from valve by removing the fasteners.
5. Mark the position of QUIK-ALIGN collar on the frame hanger.

**SERVICE HINT**

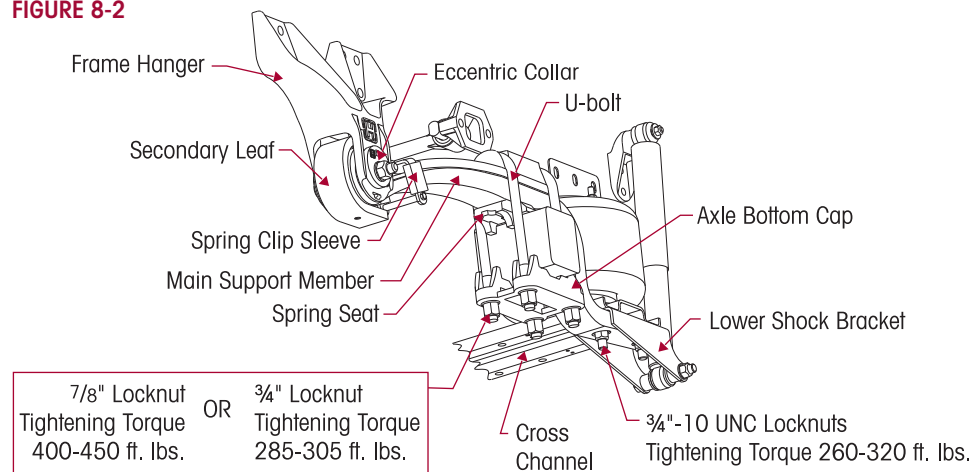
Marking the position will create a starting point for the alignment procedure following assembly.

**FIGURE 8-2**

6. Remove the 1" pivot bolt, nut and QUIK-ALIGN collars that connect the main support member assembly to the frame hanger, see Figure 8-2.
7. Remove the U-bolts, locknuts and washers.
8. Remove the axle bottom cap and top pad.
9. Remove the  $\frac{3}{4}$ " fasteners that connect the cross channel to both main support assemblies.
10. Lift cross channel off of the main support assemblies with jacks.
11. Lift and rotate the shock absorber and lower mounting bracket away from the main support assembly to be replaced.
12. Remove the main support assembly.

### ASSEMBLY

1. Position main support member assembly on spring seat, or on spacer plate (if equipped), with the main support member assembly center dowel pin piloting into hole in spring seat or spacer plate. Galvanized steel liner must be positioned on the top side of the main support member assembly.
2. Assemble the top pad, U-bolts, axle bottom cap, washers and locknuts. **DO NOT TIGHTEN** U-bolt locknuts at this time, see Figure 8-3.

**FIGURE 8-3**

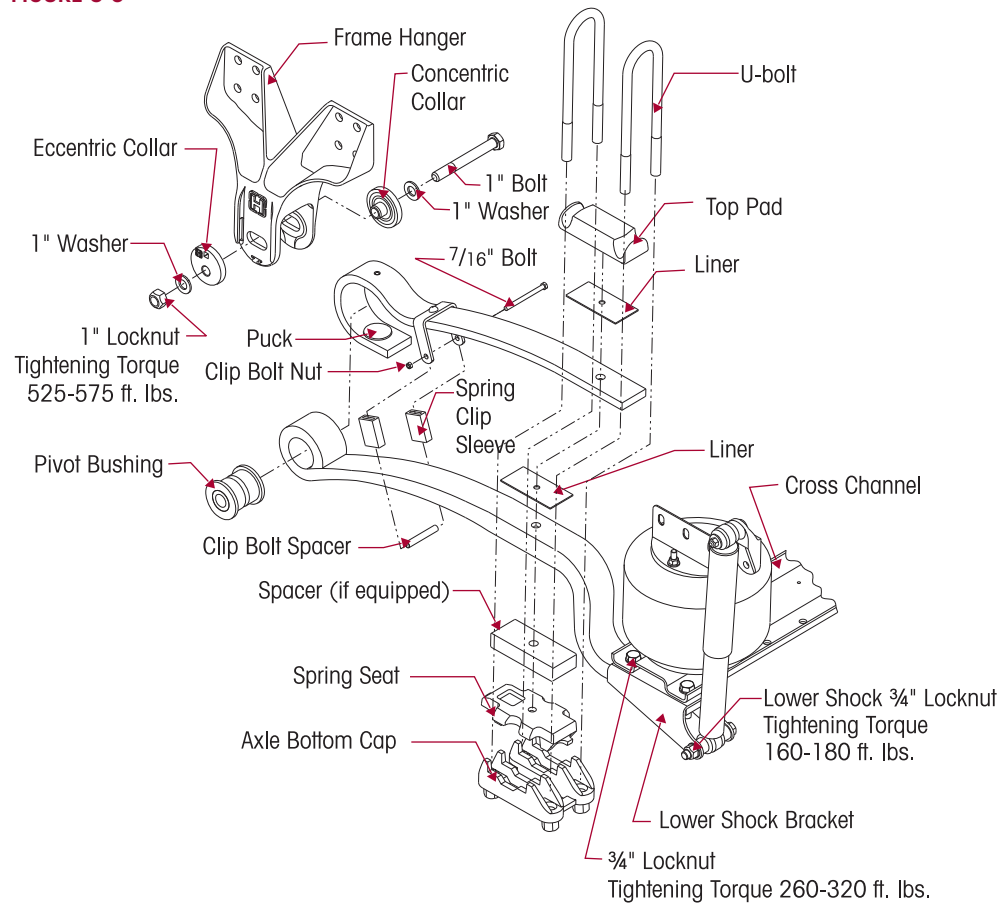

### WARNING

DO NOT ASSEMBLE QUIK-ALIGN JOINT WITHOUT PROPER FASTENERS. USE ONLY DACROMET PLUS XL PLATED FASTENERS TO SUSTAIN PROPER CLAMP FORCE. FAILURE TO DO SO CAN CAUSE LOSS OF VEHICLE CONTROL, PROPERTY DAMAGE OR PERSONAL INJURY.

3. Install NEW QUIK-ALIGN collars, NEW 1" dacromet pivot bolt, washers and locknut. Verify the nose of each QUIK-ALIGN collar is installed into the pivot-bushing sleeve, and the flanged collar is flat against the hanger face within the adjustment guides. **DO NOT TIGHTEN** at this time.

**NOTE**

The eccentric collar is located on the outside frame on the left side of chassis with the concentric collar on the inside. On the right side of chassis are (2) concentric collars located on the inside and outside of the frame hanger.

4. Position shock absorber and lower mounting bracket assembly on main support assembly.
5. Position cross channel on main support assemblies. Install ¾" bolts, washers and locknuts. Tighten to 260-320 foot pounds torque.
6. Snug 1" NEW QUIK-ALIGN locknuts to 100 foot pounds torque.

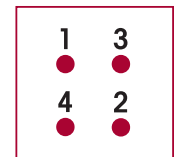
**FIGURE 8-4**

7. Tighten the U-bolt locknuts evenly in 50 foot pounds increments in proper pattern to achieve uniform bolt tension, see Figure 8-4.
8. Rap the top of U-bolts, and retighten to the proper torque. **DO NOT EXCEED SPECIFIED TORQUE ON U-BOLT LOCKNUTS.** Tighten locknuts to:
  - 19,000 to 23,000 pound capacity equipped with ⅞" locknuts tighten to 400-450 foot pounds torque.
  - 15,000 pound capacity equipped with ¾" locknuts to 285-305 foot pounds torque.
9. Remove jack stands and lower the frame of vehicle.
10. Install upper extension rod stud onto the height control valve arm. Tighten locknut to 80-90 inch pounds torque.
11. Air up the system.
12. Align rear axle (see alignment in the Alignment & Adjustments Section of this publication).
13. Remove wheel chocks.

## MAIN SUPPORT MEMBER ASSEMBLY PIVOT BUSHING

**FIGURE 8-5**

**DISASSEMBLY**
**You will need:**

- A vertical shop press with a capacity of at least 10 tons
  - A receiving tool and a push out tool, see Special Tools Section of this publication for more information.
1. Remove the ⅞" bolt, clip bolt spacer and nut from the secondary leaf spring clip.
  2. Cut the splicing tape that holds the liners to the center of the main support member assembly and rotate the secondary leaf to clear the spring clip from main support member.

3. Slide the secondary leaf off of the main support member eye.
4. Support the main support member on the receiving tool with the end hub centered on the tool. Be sure the main support member is squarely supported on the press bed, see Figure 8-5.

**NOTE**

At the time of manufacture, a spring eye clip was used to insert the pivot bushing into the spring eye of the main support member, see Figure 8-6. If spring eye clip is equipped on the main support member you have the option to carefully press out the bushing from the opposite side of the spring eye (where the spring eye clip is NOT visible). If the spring eye clip is not damaged it can be used again to facilitate the pressing in of the pivot bushing into the spring eye. If clip is damaged use the tape option as shown in Figure 8-7.

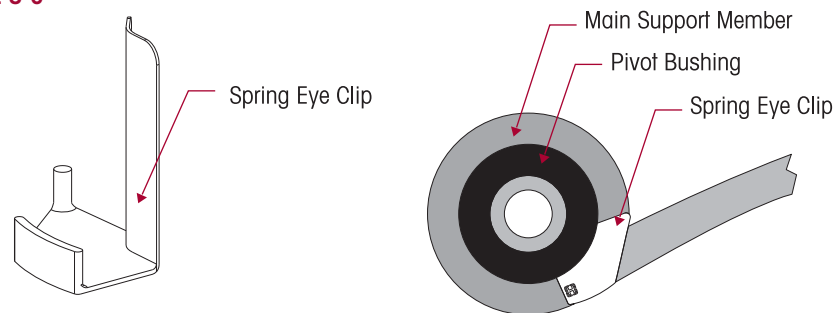
**FIGURE 8-6**

5. Center the push out tool on inner sleeve and press out the old bushing. (These bushings are not cartridge type bushings. They do not have outer metals).
6. Clean and inspect the I.D. of the main support member eye.

**ASSEMBLY**

1. Insert the spring eye clip (if equipped) into the gap of the main support member eye, (see note above). If spring eye clip is damaged or not present it is necessary to cut a strip of 3M Scotch #890T black fiber tape, or heavy bodied duct tape 1" x 6" long.
2. Feed the tape into the spring eye, adhesive side facing gap in the eye. Center the tape equally around each end.

3. Pull the tape tight, and wrap it around the outside of the eye. Additional tape may be required depending on gap size. Ensure that the gap is completely covered, see Figure 8-7.
4. Lubricate inner diameter of steel spring bore and the new rubber bushing with a vegetable base oil (cooking oil).

**DO NOT** use petroleum or soap base lubricant, it can cause an adverse reaction with the bushing material, such as deterioration.

5. Support the main support member on the receiving tool with the end hub centered on the tool. Be sure the main support member is squarely supported on the press bed.

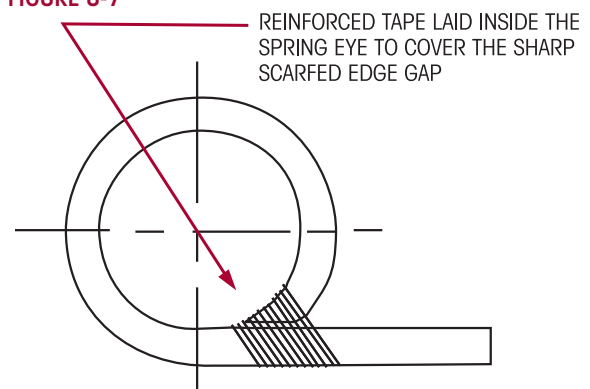
**FIGURE 8-7**

6. Locate the push out tool on inner sleeve, and press in the new bushing. Bushings must be centered within the spring eye. When pressing in the new bushings, over-shoot desired final position by  $\frac{3}{16}$ " and press again from opposite side to center the bushing within the main support member assembly, see Figure 8-8.
7. Trim all protruding tape from the underside of the eye. Wipe off excess lubricant. Allow the lubricant four hours to dissipate before operating vehicle.
8. Replace the two nylon pucks inside the secondary leaf eye.
9. Slide secondary leaf around main support member eye and rotate into position.
10. Place one liner between the secondary leaf and the main support member. Place the second liner on top of the secondary leaf and tape the assembly together using two 1" x 12" long strips of splicing tape.

FIGURE 8-8



**CAUTION**

DO NOT WRAP EXCESSIVE TAPE AROUND THE ASSEMBLY AS THIS WOULD CREATE HIGH SPOTS IN THE CLAMP GROUP. DO NOT WRAP TAPE AROUND THE ASSEMBLY MORE THAN TWICE. FAILURE TO DO SO CAN CAUSE PREMATURE WEAR OR DAMAGE TO THE MAIN SUPPORT MEMBER.

11. Install the  $\frac{7}{16}$ " bolt and nut into the spring clip and tighten to  30-34 foot pounds torque, see Figure 8-3.
12. Replace main support member assembly per instructions in this section.

### SPRING SEAT

The spring seat is unlikely to require replacement. In normal use it should function satisfactorily throughout the life of the vehicle. Replacement is required when it is damaged.

### DISASSEMBLY

1. Chock wheels of axle.
2. Raise frame of vehicle to remove load from suspension.

**WARNING**

VEHICLE MUST BE FIRMLY SUPPORTED WITH JACK STANDS PRIOR TO SERVICING. FAILURE TO DO SO CAN RESULT IN PERSONAL INJURY OR PROPERTY DAMAGE.

**WARNING**

PRIOR TO AND DURING DEFLATION AND INFLATION OF THE AIR SUSPENSION SYSTEM, ENSURE THAT ALL PERSONNEL AND EQUIPMENT ARE CLEAR FROM UNDER THE VEHICLE AND AROUND THE SERVICE AREA, FAILURE TO DO SO CAN CAUSE SERIOUS PERSONAL INJURY, DEATH, OR PROPERTY DAMAGE.

3. See additional Air Spring Cautions and Warnings in the Important Safety Notice Section of this publication prior to deflating or inflating the air system.
4. Verify air is removed from the system, and remove height control valve extension rod from valve by removing fasteners.
5. Remove the U-bolt locknuts and washers, see Figure 8-9.
6. Remove U-bolts, axle bottom cap and top pad.
7. Loosen the  $\frac{3}{4}$ " fasteners that connect the cross channel to both main support assemblies.



8. Lift cross channel and the main support member assembly with a jack.
9. Remove spring seat.

FIGURE 8-9

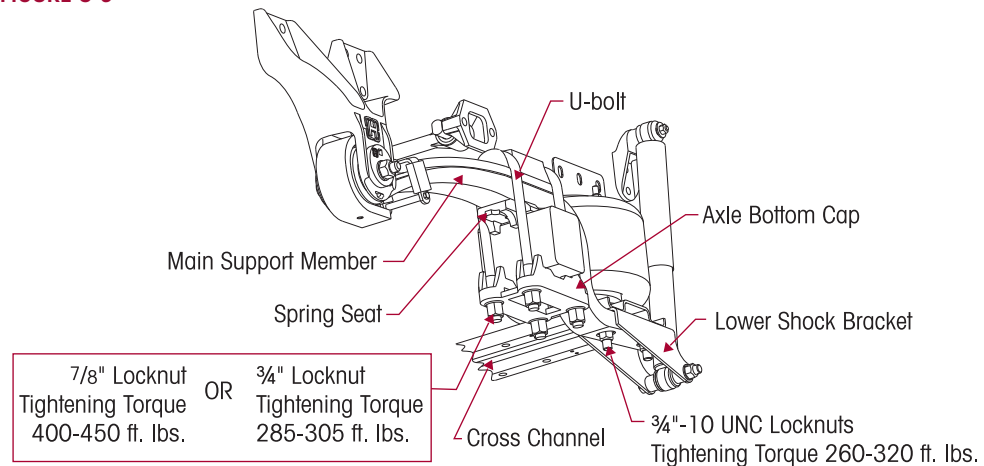

### ASSEMBLY

1. Install spring seat on axle in proper direction.
2. Position main support assembly on spring seat, or on spacer plate if so equipped, with main support assembly center dowel pin piloting into hole in spring seat or spacer plate. Delrin liner must be positioned on the topside of the main support member assembly.
3. Assemble U-bolts, axle bottom cap, washers and locknuts. **DO NOT** TIGHTEN U-bolt locknuts at this time.
4. Tighten the 3/4" bolts, washers and locknuts that connect the cross channel to the main support member assemblies to 260-320 foot pounds torque.



### WARNING

IT IS IMPORTANT THAT THE U-BOLT CLAMP GROUP CONNECTION BE PROPERLY ALIGNED AND HAVE THE PROPER TIGHTENING TORQUE VALUES MAINTAINED. METAL SURFACES CAN WORK AND WEAR AGAINST OTHER RELATED CLAMP GROUP COMPONENTS IF NOT PROPERLY ALIGNED OR PROPERLY TIGHTENED TO MAINTAIN THE PROPER CLAMP FORCE. FAILURE TO DO SO CAN CAUSE PREMATURE COMPONENT WEAR, POSSIBLE SEPARATION OF THE CLAMP GROUP, CAUSING LOSS OF VEHICLE CONTROL, PROPERTY DAMAGE, OR PERSONAL INJURY.

FIGURE 8-10

5. Tighten the U-bolt locknuts evenly in 50 foot pounds increments in proper pattern to achieve uniform bolt tension, see Figure 8-10.
6. Rap the top of U-bolts, and retighten to the proper torque. **DO NOT EXCEED SPECIFIED TORQUE ON U-BOLT LOCKNUTS.** Tighten locknuts to:
  - 19,000 to 23,000 pound capacity equipped with 7/8" locknuts tighten to 400-450 foot pounds torque.
  - 15,000 pound capacity equipped with 3/4" locknuts to 285-305 foot pounds torque.
7. Remove jack stands and lower the frame of vehicle.
8. Install height control valve link on control valve arm. Tighten 5/16" lockwasher and nut to 80-90 inch pounds torque.
9. Air up the system.
10. Remove wheel chocks.

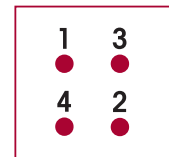



## BOTTOM CAP

The bottom cap is unlikely to require replacement. In normal use it should function satisfactorily throughout the life of the vehicle. Replacement is required when it is damaged.

### DISASSEMBLY

1. Chock wheels of axle.
2. Raise frame of vehicle to remove load from suspension.

 **WARNING**

VEHICLE MUST BE FIRMLY SUPPORTED WITH JACK STANDS PRIOR TO SERVICING. FAILURE TO DO SO CAN RESULT IN PERSONAL INJURY OR PROPERTY DAMAGE.

 **WARNING**

PRIOR TO AND DURING DEFLATION AND INFLATION OF THE AIR SUSPENSION SYSTEM, ENSURE THAT ALL PERSONNEL AND EQUIPMENT ARE CLEAR FROM UNDER THE VEHICLE AND AROUND THE SERVICE AREA, FAILURE TO DO SO CAN CAUSE SERIOUS PERSONAL INJURY, DEATH, OR PROPERTY DAMAGE.



3. See additional Air Spring Cautions and Warnings in the Important Safety Notice Section of this publication prior to deflating or inflating the air system.
4. Verify air is removed from the system.
5. Remove the U-bolt locknuts and washers.
6. Remove axle bottom cap.

### ASSEMBLY

1. Install axle bottom cap on axle in proper direction.
2. Assemble U-bolts, washers and locknuts.

 **WARNING**

IT IS IMPORTANT THAT THE U-BOLT CLAMP GROUP CONNECTION BE PROPERLY ALIGNED AND HAVE THE PROPER TIGHTENING TORQUE VALUES MAINTAINED. METAL SURFACES CAN WORK AND WEAR AGAINST OTHER RELATED CLAMP GROUP COMPONENTS IF NOT PROPERLY ALIGNED OR PROPERLY TIGHTENED TO MAINTAIN THE PROPER CLAMP FORCE. FAILURE TO DO SO CAN CAUSE PREMATURE COMPONENT WEAR, POSSIBLE SEPARATION OF THE CLAMP GROUP, CAUSING LOSS OF VEHICLE CONTROL, PROPERTY DAMAGE, OR PERSONAL INJURY.

3. Tighten the U-bolt locknuts evenly in 50 foot pounds increments in proper pattern to achieve uniform bolt tension, see Figure 8-10.
4. Rap the top of U-bolts, and retighten to the proper torque. **DO NOT EXCEED SPECIFIED TORQUE ON U-BOLT LOCKNUTS.** Tighten locknuts to:
  - 19,000 to 23,000 pound capacity equipped with 7/8" locknuts tighten to  400-450 foot pounds torque.
  - 15,000 pound capacity equipped with 3/4" locknuts to  285-305 foot pounds torque.
5. Remove jack stands and lower the frame of vehicle.
6. Air up the system.
7. Remove wheel chocks.

## AIR SPRING

### DISASSEMBLY

1. Chock wheels of axle.
2. Raise frame of vehicle to remove load from suspension.



#### WARNING

VEHICLE MUST BE FIRMLY SUPPORTED WITH JACK STANDS PRIOR TO SERVICING. FAILURE TO DO SO CAN RESULT IN PERSONAL INJURY OR PROPERTY DAMAGE.



#### WARNING

PRIOR TO AND DURING DEFLATION AND INFLATION OF THE AIR SUSPENSION SYSTEM, ENSURE THAT ALL PERSONNEL AND EQUIPMENT ARE CLEAR FROM UNDER THE VEHICLE AND AROUND THE SERVICE AREA, FAILURE TO DO SO CAN CAUSE SERIOUS PERSONAL INJURY, DEATH, OR PROPERTY DAMAGE.

3. See additional Air Spring Cautions and Warnings in the Important Safety Notice Section of this publication prior to deflating or inflating the air system.
4. Verify air is removed from the system.

5. Remove the ½" fasteners that connect air spring to the cross channel, see Figure 8-11.
6. Remove air line from air spring.
7. Remove brass fittings from air spring.
8. Remove the ½" fasteners that connect air spring to the upper air spring hanger.
9. Remove air spring.

### ASSEMBLY

1. Install air spring in upper air spring hanger by inserting stud into hole and attach the ½" washer and locknut.
2. Install air spring in spring seat by inserting stud into hole and attach the ½" washer and locknut.
3. Tighten ½" locknuts to 20-30 foot pounds torque.
4. Install brass fitting in air spring using Teflon thread seal.
5. Connect air line to air spring.
6. Remove jack stands and lower frame of vehicle.
7. Air up system.
8. Remove wheel chocks.

FIGURE 8-11

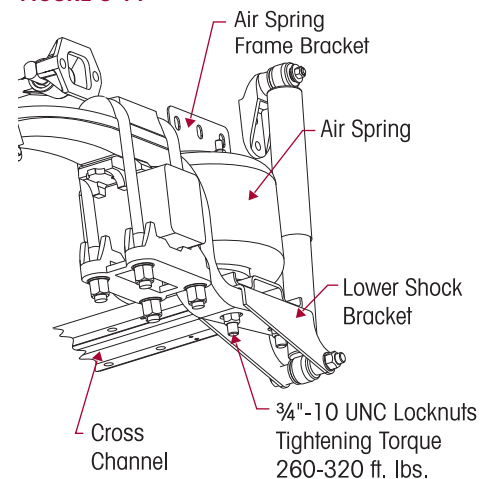

## CROSS CHANNEL

### DISASSEMBLY

1. Chock wheels of axle.
2. Raise frame of vehicle to remove load from suspension.



#### WARNING

VEHICLE MUST BE FIRMLY SUPPORTED WITH JACK STANDS PRIOR TO SERVICING. FAILURE TO DO SO CAN RESULT IN PERSONAL INJURY OR PROPERTY DAMAGE.

**WARNING**

PRIOR TO AND DURING DEFLATION AND INFLATION OF THE AIR SUSPENSION SYSTEM, ENSURE THAT ALL PERSONNEL AND EQUIPMENT ARE CLEAR FROM UNDER THE VEHICLE AND AROUND THE SERVICE AREA, FAILURE TO DO SO CAN CAUSE SERIOUS PERSONAL INJURY, DEATH, OR PROPERTY DAMAGE.

3. See additional Air Spring Cautions and Warnings in the Important Safety Notice Section of this publication prior to deflating or inflating the air system.
4. Verify air is removed from the system.
5. Remove the 1/2" fasteners that connect air springs to the cross channel, and push air springs out of cross channel.
6. Remove the 1/4" fasteners that connect the lower linkage mounting bracket to the cross channel. See Parts Lists Section of this publication.
7. Remove the 3/4" fasteners that connect the cross channel to the main support member assemblies.
8. Remove cross channel.

**ASSEMBLY**

1. Install the cross channel to the lower shock brackets and main support member assemblies by attaching the 3/4" bolts, washers and locknuts. Tighten to 260-320 foot pounds torque.
2. Install air springs in cross channel by inserting studs into appropriate holes and attach washers and locknuts. Tighten 1/2" locknuts to 20-30 foot pounds torque.
3. Install the lower linkage mounting bracket to the cross channel by attaching the 1/4" bolts, washers and locknuts. Tighten 1/4" locknuts to 40-50 inch pounds torque.
4. Remove jack stands and lower frame of vehicle.
5. Air up system.
6. Remove wheel chocks.

**SHOCK ABSORBER**
**DISASSEMBLY**

1. Remove the 1/2" fasteners, that connect shock absorber to frame hanger, see Figure 8-12.
2. Remove the 3/4" fasteners that connect shock absorber to lower shock bracket.
3. Remove shock absorber.

**ASSEMBLY**

1. Install shock absorber to frame bracket stud by attaching 1/2" washers and locknut. Washers must be installed on each side of shock absorber bushing.
2. Install shock absorber to lower shock bracket by attaching the 3/4" bolt, washers, and locknut.
3. Tighten 1/2" locknut to 50-70 foot pounds torque, and 3/4" locknut to 160-180 foot pounds torque.

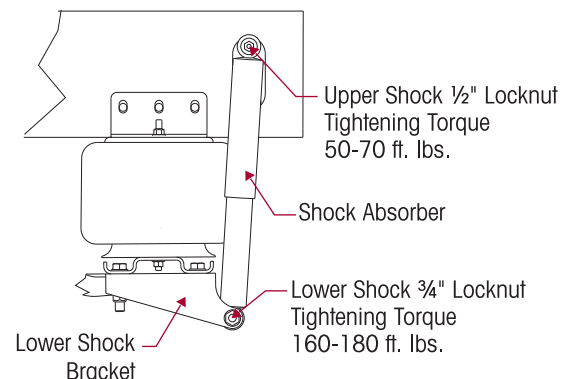

**FIGURE 8-12**

## UPPER SHOCK BRACKET

### DISASSEMBLY

1. Remove the 1/2" fasteners, that connect shock absorber to upper shock bracket.
2. Remove the 3/4" fasteners that connect shock absorber to lower shock bracket.
3. Remove shock absorber.
4. Remove the fasteners that attach the upper shock frame bracket per vehicle manufacturer specifications.
5. Remove frame bracket.

### ASSEMBLY

1. Install the upper shock bracket by attaching the fasteners per vehicle manufacturer specifications.
2. Install shock absorber to upper shock bracket stud by attaching 1/2" washers and locknut. Washers must be installed on each side of shock absorber bushing.
3. Install shock absorber to lower shock bracket by attaching the 3/4" bolt, washers, and locknut.
4. Tighten 1/2" locknut to  50-70 foot pounds torque, and 3/4" locknut to  160-180 foot pounds torque.

## LOWER SHOCK BRACKET

### DISASSEMBLY

1. Chock wheels of axle.
2. Raise frame of vehicle to remove load from suspension.



#### WARNING

VEHICLE MUST BE FIRMLY SUPPORTED WITH JACK STANDS PRIOR TO SERVICING. FAILURE TO DO SO CAN RESULT IN PERSONAL INJURY OR PROPERTY DAMAGE.



#### WARNING

PRIOR TO AND DURING DEFLATION AND INFLATION OF THE AIR SUSPENSION SYSTEM, ENSURE THAT ALL PERSONNEL AND EQUIPMENT ARE CLEAR FROM UNDER THE VEHICLE AND AROUND THE SERVICE AREA, FAILURE TO DO SO CAN CAUSE SERIOUS PERSONAL INJURY, DEATH, OR PROPERTY DAMAGE.

3. See additional Air Spring Cautions and Warnings in the Important Safety Notice Section of this publication prior to deflating or inflating the air system.
4. Verify air is removed from the system.
5. Remove the 1/2" fasteners that connect the shock absorber to the upper frame bracket.
6. Remove the 3/4" fasteners that connect the shock absorber to the lower bracket, see Figure 8-12.
7. Remove the shock absorber.
8. Remove the 3/4" fasteners that connect the cross channel and lower shock bracket to the main support member assembly on the affected side. Loosen the 3/4" bolts, washers and locknuts on the opposite side.
9. Remove lower shock bracket.

### ASSEMBLY

1. Install the lower shock bracket to the cross channel and main support member assembly by attaching the 3/4" bolts, washers and locknuts. Tighten 3/4" locknuts to  260-320 foot pounds torque.

2. Install shock absorber to frame bracket stud by attaching washers and ½" locknut. Washers must be installed on each side of shock absorber bushing.
3. Install shock absorber to lower shock bracket by attaching the ¾" bolt, washers, and locknut.
4. Tighten ½" locknut to 50-70 foot pounds torque, and ¾" locknut to 160-180 foot pounds torque.
5. Remove jack stands and lower frame of vehicle.
6. Air up system.
7. Remove wheel chocks.

## HEIGHT CONTROL VALVE

### DISASSEMBLY

1. Chock wheels of axle.
2. Raise frame of vehicle to remove load from suspension.

**WARNING**

VEHICLE MUST BE FIRMLY SUPPORTED WITH JACK STANDS PRIOR TO SERVICING. FAILURE TO DO SO CAN RESULT IN PERSONAL INJURY OR PROPERTY DAMAGE.

**WARNING**

PRIOR TO AND DURING DEFLATION AND INFLATION OF THE AIR SUSPENSION SYSTEM, ENSURE THAT ALL PERSONNEL AND EQUIPMENT ARE CLEAR FROM UNDER THE VEHICLE AND AROUND THE SERVICE AREA, FAILURE TO DO SO CAN CAUSE SERIOUS PERSONAL INJURY, DEATH, OR PROPERTY DAMAGE.

3. See additional Air Spring Cautions and Warnings in the Important Safety Notice Section of this publication prior to deflating or inflating the air system.
4. Verify air is removed from the system.
5. Remove the ⅝" fasteners that attach the extension rod to the height control valve arm.
6. Remove the air lines from the height control valve.
7. Remove the brass fittings from the height control valve.
8. Remove the ¼" fasteners, that attach the height control valve to the frame mounting bracket.
9. Remove the height control valve, see Figure 8-13.

**FIGURE 8-13**

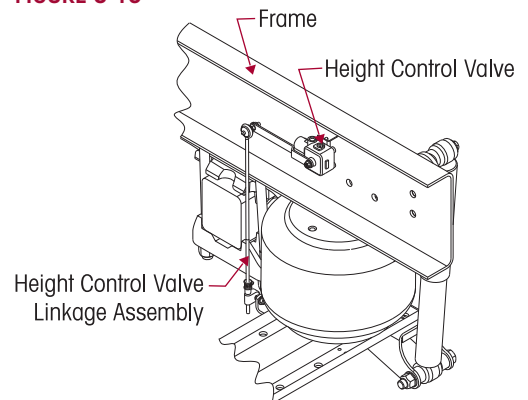

### ASSEMBLY

1. Install the height control valve to the frame mounting bracket by attaching the ⅝" washers and locknuts. Tighten to 80-90 inch pounds torque.
2. Install brass fittings into height control valve using Teflon thread seal.
3. Install air lines to height control valve.
4. Install the height control valve link assembly to the height control valve arm by attaching the ⅝" washer and locknut. Tighten to 80-90 inch pounds torque.
5. Remove jack stands and lower frame of vehicle.
6. Air up system.

7. Verify proper ride height, (see Ride Height Setting in the Alignment & Adjustments Section of this publication).
8. Remove wheel chocks.

## TRANSVERSE TORQUE ROD

### DISASSEMBLY

1. Chock the wheels.
2. Remove the  $\frac{5}{8}$ " fasteners that connect the transverse torque rod to the frame bracket and axle.
3. Remove transverse torque rod.

### ASSEMBLY

#### NOTE

Hendrickson requires the use of Grade 8 bolts and Grade C locknuts be used for all torque rod attachments.

1. Install transverse torque rod by attaching the  $\frac{5}{8}$ " bolts, washers, and locknuts to the frame bracket and axle. See manufacturers for torque specifications.
2. Verify lateral axle alignment, and correct with drop in shims between the torque rod bar pin and the frame or axle bracket depending on the direction of alignment.
3. Remove wheel chocks.

## TRANSVERSE TORQUE ROD BUSHING

### DISASSEMBLY

#### You will need:

- A vertical press with a capacity of at least 10 tons
- A receiving tool, see Special Tools Section of this publication



#### CAUTION

DO NOT USE HEAT OR USE A CUTTING TORCH TO REMOVE THE BUSHINGS FROM THE TORQUE ROD. THE USE OF HEAT WILL ADVERSELY AFFECT THE STRENGTH OF THE TORQUE ROD, HEAT CAN CHANGE THE MATERIAL PROPERTIES. A COMPONENT DAMAGED IN THIS MANNER CAN RESULT IN THE LOSS OF VEHICLE CONTROL AND POSSIBLE PERSONAL INJURY OR PROPERTY DAMAGE.

1. Remove transverse torque rod as detailed in this section.
2. Support the torque rod end on the receiving tool with the end tube of torque rod centered on the tool. Be sure the torque rod is squarely supported on the press bed.
3. Push directly on the bushing straddle mount bar pin until top of the bushing is level to the top of torque rod end tube. Press until the bushing clears the torque rod end tube.
4. Clean and inspect the inner diameter of the torque rod ends, removing any nicks with an emery cloth or a rotary sander, see Figure 8-14.

### ASSEMBLY

1. Lubricate the inner diameter of the torque rod ends and the new rubber bushings with a vegetable base oil (cooking oil), see Figure 8-15.

#### NOTE

**DO NOT** use petroleum or soap base lubricant, it can cause an adverse reaction with the bushing, such as deterioration of the rubber.

5. Press in the new bushings. Support the torque rod end tube on the receiving tool with the end tube of torque rod centered on the receiving tool.

**NOTE**

The straddle mount bar pin bushings must have the mounting flats positioned at zero degrees to shank of the torque rod.

6. Press directly on the straddle mount bar pin of bushing. The rubber bushings of the bar pin must be centered within the torque rod end tubes.
7. When pressing in the new bushings, overshoot the desired final position by approximately  $\frac{3}{16}$ ", see Figure 8-16.
8. Press the bushing again from opposite side to center the bar pin within the torque rod end, see Figure 8-17.
9. Wipe off excess lubricant. Allow the lubricant four hours to dissipate before operating vehicle.

**CAUTION**

IF THE TORQUE ROD ASSEMBLY IS NOT ALLOWED THE ALLOTTED TIME FOR THE LUBRICANT TO DISSIPATE, THE BUSHING MAY SLIDE FROM THE TORQUE ROD END TUBE. THE BUSHING WILL THEN NEED TO BE REMOVED AND A NEW BUSHING RE-INSTALLED.

10. Replace torque rod assembly as detailed in this section.

**FIGURE 8-14**

**FIGURE 8-15**

**FIGURE 8-16**

**FIGURE 8-17**

# SECTION 9 Plumbing Diagram

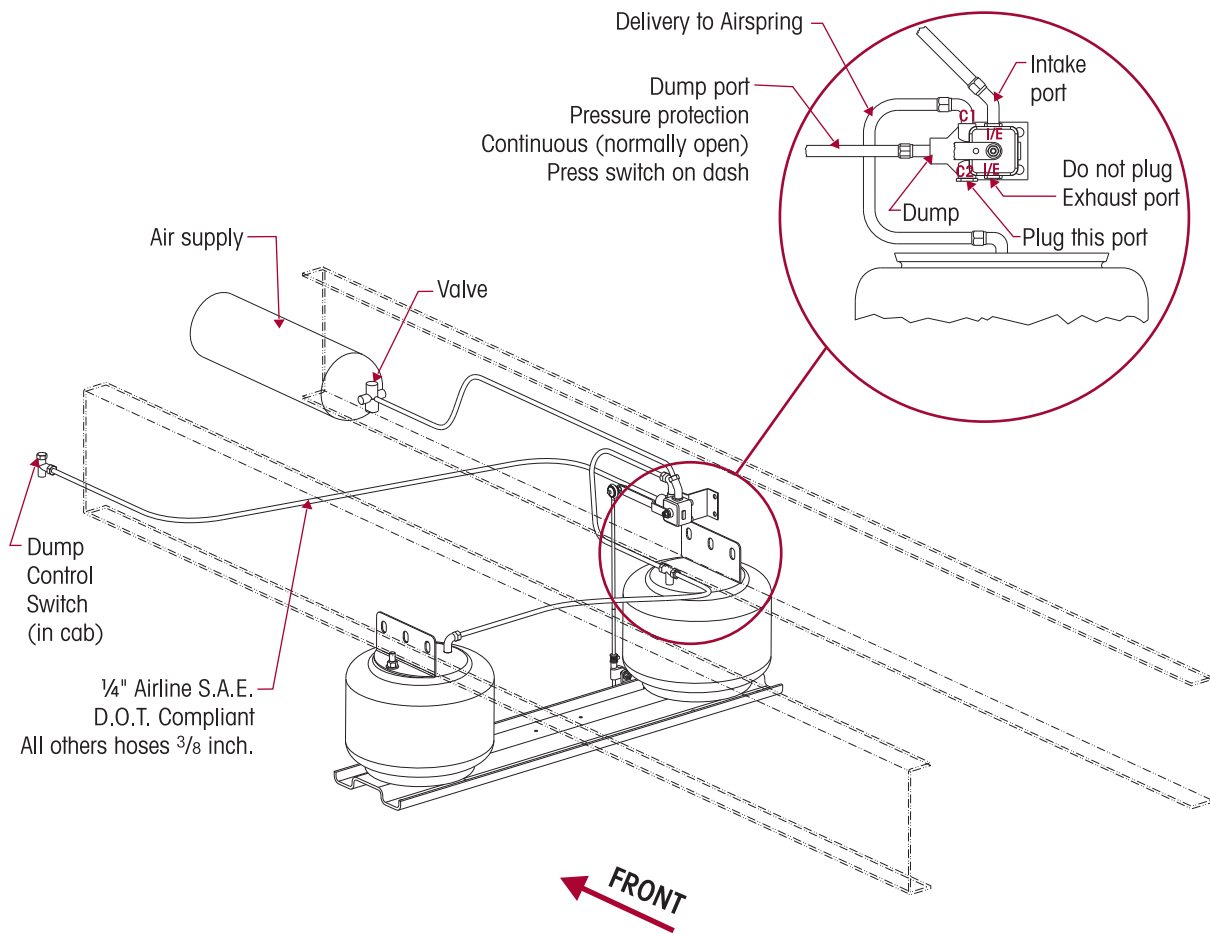





## SECTION 10

# Troubleshooting Guide

COMFORT AIR TROUBLESHOOTING GUIDE		
CONDITION	POSSIBLE CAUSE	CORRECTION
Vehicle bouncing excessively	Leaking shock absorber	Replace shock absorber
	Damaged shock absorber	Replace shock absorber
	Air spring(s) not inflated	Check air supply to air spring, repair as necessary
	Incorrect ride height	Adjust ride height to proper setting. See Ride Height Setting in the Alignment & Adjustments Section of this publication
Suspension has harsh or bumpy ride	Broken main support member assembly	Replace main support member assembly
	Damaged height control valve	Replace height control valve
Excessive driveline vibration	Incorrect ride height	Adjust ride height to proper setting. See Ride Height Setting in the Alignment & Adjustments Section of this publication
	Broken main support member assembly	Replace main support member assembly
	Air spring(s) not inflated	Check air supply to air spring, repair as necessary
Vehicle leans	Broken main support member assembly	Replace main support member assembly
	Axle connection not torqued correctly	Perform U-bolt retorque procedure. See Torque Specifications Section of this publication
	Worn pivot bushing	Replace pivot bushing
	Air spring(s) not inflated	Check air supply to air spring, repair as necessary
Suspension is noisy	Loose QUIK-ALIGN attachment	Replace QUIK-ALIGN connection and check suspension alignment. Check frame hanger for wear around QUIK-ALIGN plates and replace if necessary
	Loose U-bolts	Perform U-bolt retorque procedure. See Torque Specifications Section of this publication
	Worn main support member eye spacers	Replace worn main support member eye spacers (pucks)
	Worn main support member clip spacers	Replace worn main support member clip spacers (sleeves)
Irregular tire wear	Worn pivot bushing	Replace pivot bushing
	Loose QUIK-ALIGN attachment	Replace QUIK-ALIGN connection and check suspension alignment. Check frame hanger for wear around QUIK-ALIGN plates and replace if necessary

# SECTION 11

## Torque Specifications

RECOMMENDED TORQUE VALUES PROVIDED IN FOOT POUNDS

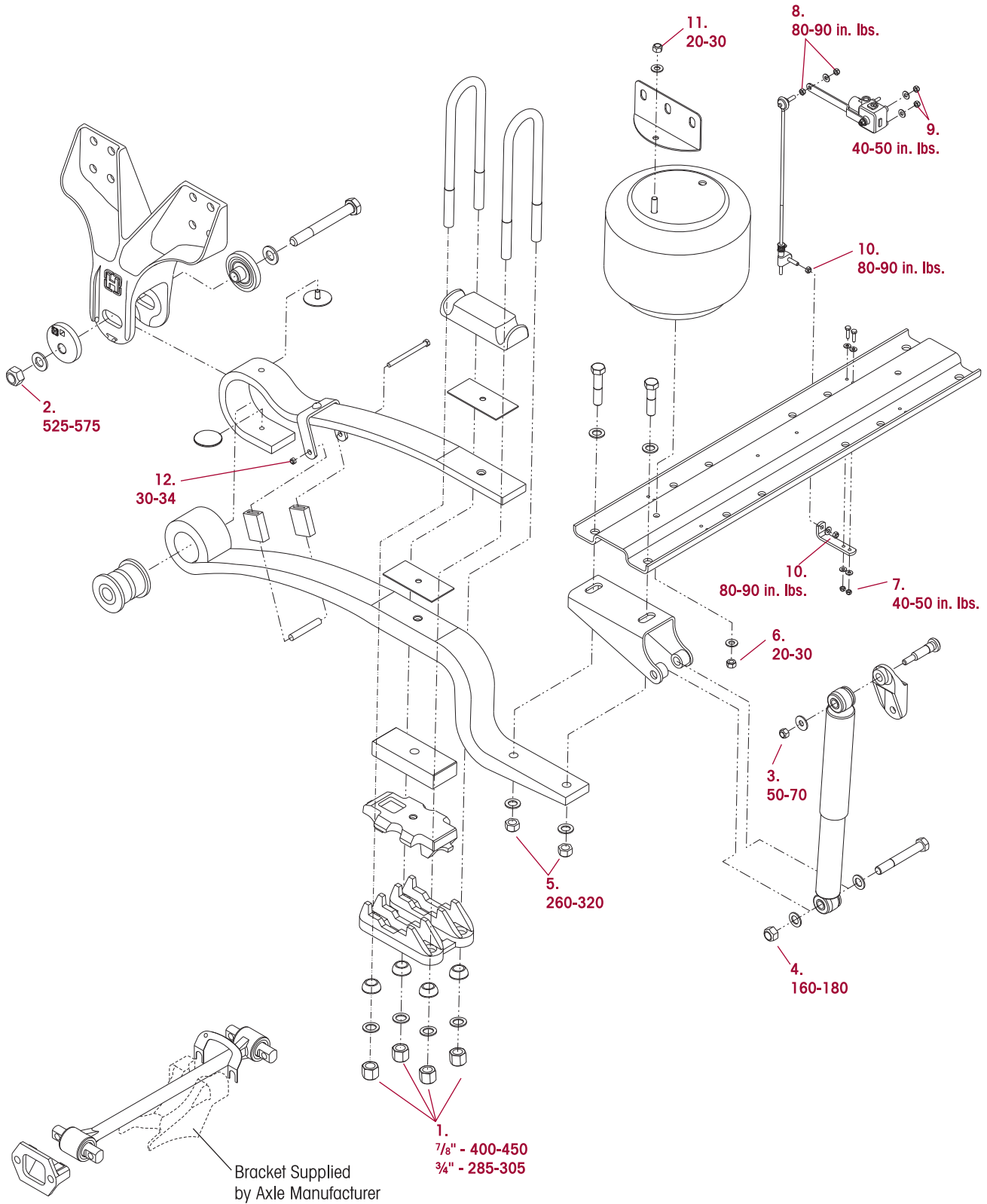



## COMFORT AIR®

HENDRICKSON RECOMMENDED TORQUE SPECIFICATIONS					
NO	COMPONENT	QUANTITY	SIZE	TORQUE VALUE (in foot pounds)	
*Frame fasteners furnished and installed by truck manufacturer					
1	U-bolt (high locknut)	19,000 to 23,000 lb. Capacity	8	7/8"	400-450
		15,000 lb. Capacity	8	3/4"	285-305
2	QUIK-ALIGN® Locknut	4	1"	525-575	
 <b>WARNING</b> DO NOT ASSEMBLE QUIK-ALIGN JOINT WITHOUT PROPER FASTENERS. USE ONLY DACROMET PLUS XL PLATE FASTENERS TO MAINTAIN PROPER CLAMP FORCE. FAILURE TO DO SO CAN CAUSE LOSS OF VEHICLE CONTROL, PROPERTY DAMAGE OR PERSONAL INJURY.					
3	Shock Absorber to Upper Shock Bracket	2	1/2"	50-70	
4	Shock Absorber to Lower Shock Bracket	2	3/4"	160-180	
5	Cross Channel to Main Support Member	4	3/4"	260-320	
6	Air Spring to Cross Channel	2	1/2"	20-30	
7	HCV Linkage Bracket to Cross Channel	2	1/4"	40-50 in. lbs.	
8	HCV Linkage to Height Control Valve Arm	2	5/16"	80-90 in lbs.	
9	Hight Control Valve to Frame Bracket	2	1/4"	40-50 in. lbs.	
10	HCV Linkage to HCV Linkage Bracket	2	5/16"	80-90 in. lbs.	
11	Air Spring to Frame Bracket	2	1/2"	20-30	
12	Main Support Member Spring Clip	2	7/16"	30-34	
<b>NOTE:</b> * Torque values listed above apply only if Hendrickson supplied fasteners are used. If non-Hendrickson fastenres are used, follow torque specification listed in the vehicle manufacturer's service manual.					

---

[www.hendrickson-intl.com](http://www.hendrickson-intl.com)



Truck Suspension Systems  
800 South Frontage Road  
Woodridge, IL 60517-4904 USA

630.910.2800  
Fax 630.910.2899