



No: 97117-234

Subject: Primaax Extreme Maintenance Free Joint

Date: JULY 2011

Revision: A

### IMPORTANT NOTICE

The Primaax Extreme (EX) Suspension Systems currently in service are configured with an integrated end cap. The latest release Primaax EX is fitted with a tamper resistant bolt cover, (Figure 1) whilst the early release Primaax EX is fitted without a tamper resistant cover (Figure 2).

Hendrickson International now advise that all Primaax EX suspension systems, including suspensions fitted without a tamper resistant bolt cover, no longer require a torque check at production, pre-delivery or any other preventative maintenance activity.

The Primaax EX Torque Table (Technical Bulletin 97117-225B) is now amended to reflect the latest preventative maintenance torque requirements. The Primaax EX support beam and cross tube connection preventative maintenance is now restricted to visual inspection only.

FIGURE 1

**Primaax EX Integrated End Cap.  
Fitted with Tamper Resistant Cover.**

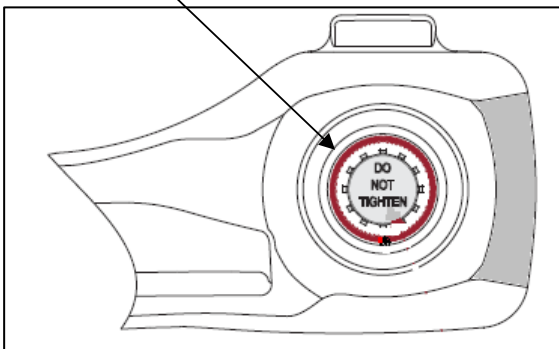
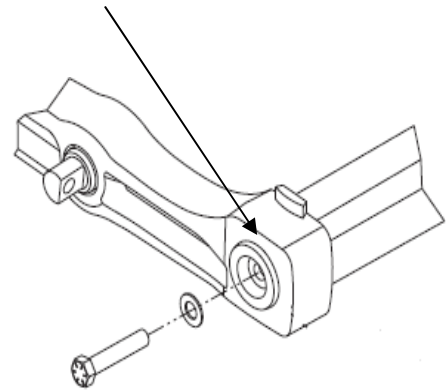

FIGURE 2

**Primaax EX Integrated End Cap.  
Without Tamper Resistant Cover**



**Any questions in relation to this Technical Bulletin please forward to the Hendrickson Product Support Group: Telephone (03) 8792 3600 or email to: [technicalservice@hendrickson.com.au](mailto:technicalservice@hendrickson.com.au)**

*Information contained in this literature was accurate at the time of publication, product changes may have been made after the publication date that are not reflected here*