

TECHNICAL BULLETIN

Intraax, HT Series TRAILER AIR SUSPENSION

No: 97117-101

Subject: *Hanger Repair Procedure*

Date: July 2003

Revision: A

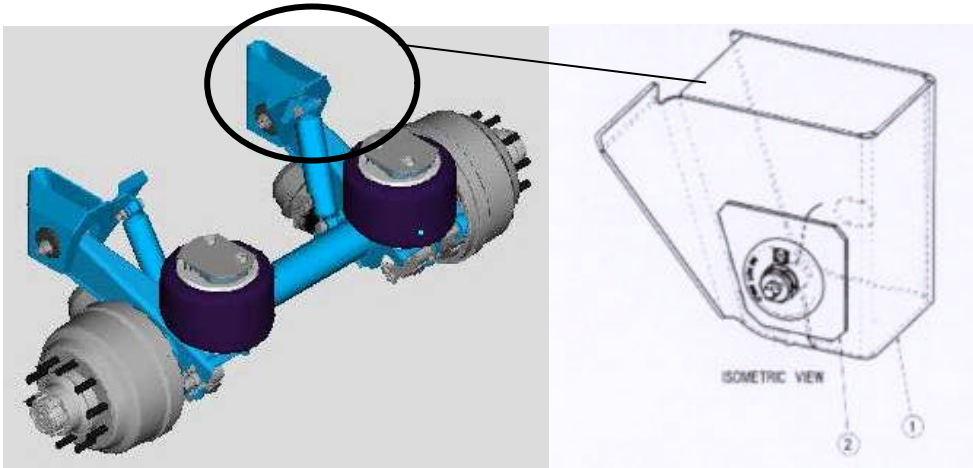

As part of our continuous product improvement program, Hendrickson wish to advise that in severe service applications, the hangers may develop cracks on the inner faces.
This general repair information is for Intraax and HT Series suspensions.

HANGER REINFORCEMENT

Hangers affected by this problem can be repaired by the addition of a reinforcing plate being fitted to the inner faces of the hanger.

These plates are available as a kit 98544-024 and one per hanger is required.

The fitment of a cross channel between the hangers is advised to prevent re-occurrence.

PROCEDURE

Place a mark on both the Quik-Align Collar and the hanger.

This will allow assembly without having to have the axle realigned.

Undo the pivot bolt and remove from trailer.

Clean off paintwork on the inner edge of the hanger.

“Vee” out the crack and weld.

Smooth off the weld and place the reinforcing place over the Quik-Align Slot making sure there is equal gap all round.

Firmly clamp the reinforcing plate to the hanger and weld as per the attached procedure.

Reassemble using a new pivot bolt and nut.

Align the marks previously made on the outer edge of the hanger and Quik-Align Collar.

Torque correctly using the special 1” socket (Part No S-25119) designed for this purpose.

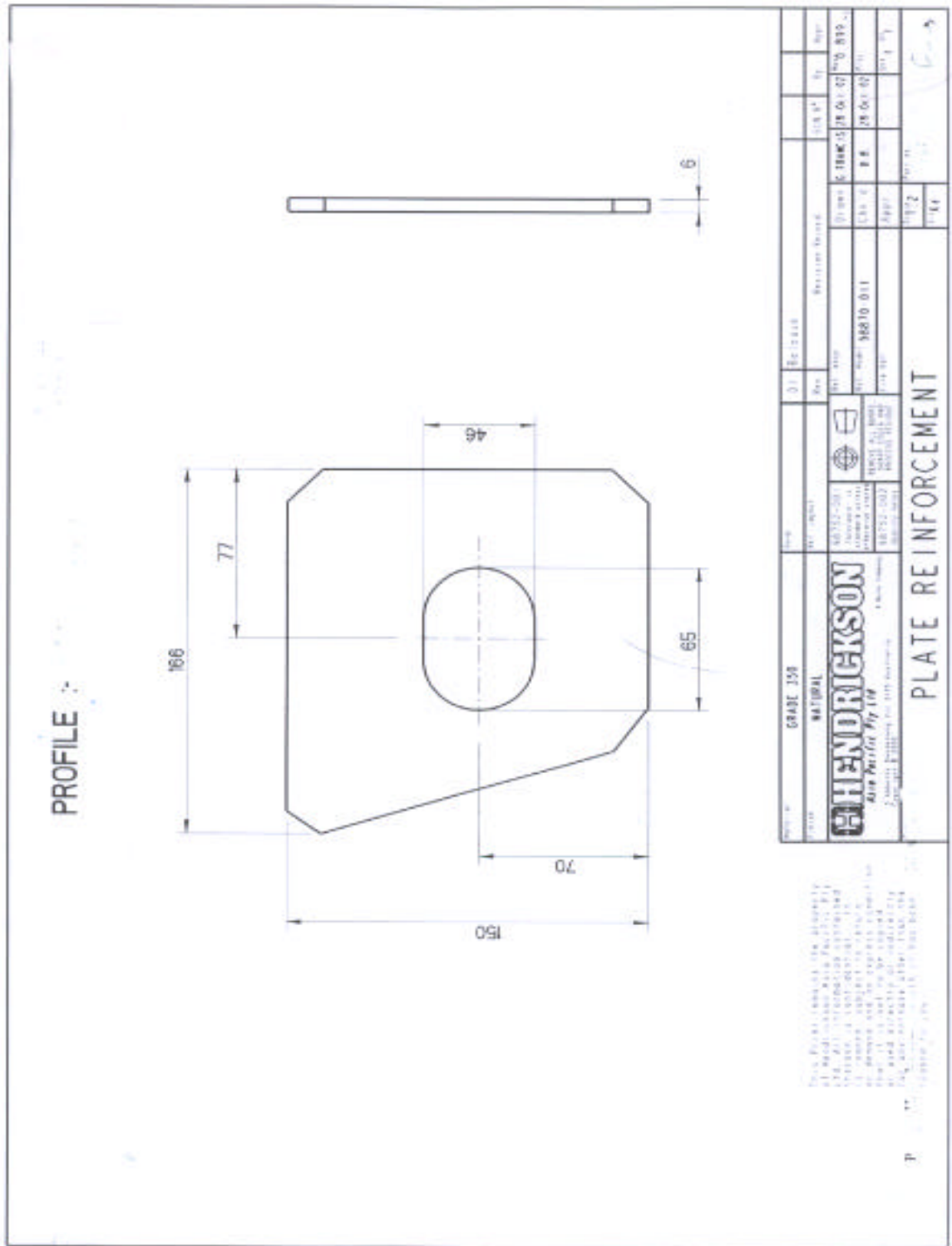

If further assistance is required, contact the Hendrickson Product Support Department on 03 9767 3400 or technicalservice@hendrickson.com.au

WARNING - HENDRICKSON REMINDS USERS NOT TO MODIFY PARTS OTHER THAN OUTLINED IN THIS PUBLICATION.